



Osprey-540 Capture Device User's Guide

For Windows XP, Windows 2000, and Windows NT 4.0

Releases 2.1.5 and later

© Copyright 2000-2002
All Rights Reserved.

ViewCast Corporation
Osprey Technologies Division
600 Airport Boulevard, Suite 900
Morrisville, NC 27560 USA

Revised March, 2002

Copyright, Trademark, and FCC Information

Copyright

This document is copyrighted by Osprey Technologies, Inc., a wholly-owned subsidiary of ViewCast Corporation. No part of this specification may be reproduced, transcribed, transmitted or stored in a retrieval system in any part or by any means without the express written consent of Osprey Technologies, Inc.

Disclaimer

Osprey Technologies, Inc. reserves the right to change any products herein at any time and without notice. ViewCast Corporation and Osprey Technologies, Inc. make no representations or warranties regarding the content of this document, and assume no responsibility for any errors contained herein.

Trademark Acknowledgment

Osprey-500, Osprey-540, and SimulStream are trademarks of Osprey Technologies, Inc. Microsoft, Windows XP, Windows 2000, Windows NT, NetMeeting, NetShow, and Video for Windows are trademarks or registered trademarks of Microsoft Corporation. Any other product names, trademarks, trade names, service marks, or service names owned or registered by any other company and mentioned herein are the property of their respective companies.

FCC Notice

This equipment has been tested and found to comply with the limits for a Class B digital device, pursuant to part 15 of the FCC Rules. These limits are designed to provide reasonable protection against harmful interference in a residential installation. This equipment generates, uses, and can radiate radio frequency energy and, if not installed and used in accordance with the instructions, may cause harmful interference to radio communications. However, there is no guarantee that interference will not occur in a particular installation.

If this device does cause harmful interference to radio or television reception, which can be determined by turning the equipment off and on, the user is encouraged to try to correct the interference by one or more of the following measures:

- ◆ Reorient or relocate the receiving antenna.
- ◆ Increase the separation between the computer and the receiver.
- ◆ Connect the computer into an outlet on a circuit different from that to which the receiver is connected.
- ◆ Consult the dealer or an experienced radio/TV technician for help.

Shielded Cables

Connections between this device and peripherals must be made using shielded cables in order to maintain compliance with FCC radio emission limits.

Modifications

Modifications to this device not approved by Osprey Technologies, Inc. could void the authority granted to the user by the FCC to operate the device.

Table of Contents

Chapter 1 - Getting to Know the Osprey-540 Capture Card..... 11

Symbols	11
Introduction	11
Features	12
Audio/Video Specifications	13
Video Input	13
Audio Input	14
Video/Audio Output	14
Audio Processing	14
Hardware Video Processing	14
Computing Platforms	15
Hardware System.....	15
Video Frame Rates and Performance	15
Software Included.....	16
Compatible Third-Party Applications	16
Getting Help.....	16

Chapter 2 - Osprey-540 Hardware 19

System Requirements	19
Configuring the Video Capture Driver	20
Installing the Card	20
Connecting Cables	21
Osprey-540 Input Breakout Cable	22
Osprey-540 Output Breakout Cable	23
Rack-mount Panel	23
Connecting a Composite Source	24
Connecting an S-Video Source	24
Connecting an SDI Source for the Osprey-540	24
Connecting an IEEE-1394 Source for the Osprey-540	24
Connecting Audio with the Osprey-540	24

Chapter 3 - Installing the Software - Windows 2000 25

Basics: Installing From CD	26
Basics: Downloading and Installing Updated Drivers	26
Canceling Out of the Found New Hardware Wizard	27
Two Install Scenarios	29
Scenario 1: Osprey Card(s) not Physically Installed in the PC	30

Scenario 2: Osprey Card(s) Physically Installed, but Osprey Software not Installed	34
Option A: Run the Installation Program (Recommended).....	34
Option B: Use the Found New Hardware Wizard (Not Recommended)	40
Indeo	48
Testing the Installation for Windows 2000	49
Uninstalling the Software.....	49
Chapter 4 – Installing the Software – Windows XP	51
Basics: Installing From CD	51
Basics: Downloading and Installing Updated Drivers	52
Two Install Scenarios	53
Scenario 1: Osprey Card(s) not Physically Installed in the PC	54
Scenario 2: Osprey Card(s) Physically Installed, but Osprey Software not Installed	59
Option A: Run the Installation Program (Recommended).....	59
Option B: Use the Found New Hardware Wizard (Not Recommended)	64
Indeo	68
Testing the Installation for Windows XP	69
Uninstalling the Software.....	69
Chapter 5 - Installing the Software - Windows NT 4.0.....	71
Installing from CD	72
Downloading and Installing Updated Drivers	72
Setup Program: Details	73
Testing the Installation for Windows NT.....	75
Uninstalling the Software.....	75
Chapter 6 - Osprey-540 Video Control Dialog	77
Accessing the Dialog	77
General Features of the Dialog	79
OK.....	79
Cancel.....	79
Restore Defaults	80
Restore Previous.....	80
Help	80
The Source Page.....	80
Input.....	81
Video Standard.....	81
Video Settings	82

Bypass Color Correction.....	82
The Format Page	83
Color Format	84
Video Size.....	84
Custom Size	85
Proportion (Pixel Aspect Ratio)	85
Cropping.....	85
The Closed Caption Page	86
Display on Screen	87
Save to File.....	88
Mode.....	88
Channel	88
Text Color.....	88
Apply to All Boards.....	89
The Logo Page.....	89
Capabilities	90
Step 0 - Before You Start.....	90
Step 1 - Creating and Enabling the Logo	91
Step 2 - Selecting the Logo File	92
Step 3 - Setting Key Color and Style	93
Step 4 - Positioning the Logo.....	94
Step 5 - Reviewing and Saving the Changes.....	95
Notes on Logos.....	96
Apply to All Boards.....	97
The Advanced Features Page.....	97
Field Order	97
The De-Interlacing Motion Filter.....	98
The Transfer Mode	100
The Configuration Page	103
Overlays	103
Access to the Format Tab.....	104
Multiple Opens.....	104
Default Capture Device.....	105
The SimulStream Page	105
Cropping and Scaling	106
Chapter 7 - Capturing Audio	107
Selecting the Audio Source and Input Volume	107
Registry Settings Controlling other Audio Parameters	109
Rate Conversion Method	109
Gain Selection	110

Audio Formats.....	110
Missing Digital Audio Sources	111
Audio Playback	111

Chapter 8 – VidCap32, AmCap, and Included Demo Programs113

VidCap32.....	113
Preview	114
Overlay	114
Single Frame Capture	114
Configuring the Video Capture Driver	114
Compression	115
Setting the Capture File - Preallocating and Defragmenting	115
Capturing Video	116
Playback	117
AmCap	117
Selecting the AmCap Device.....	118
AmCap Preview	119
Configuring the Video Capture Driver in AmCap	119
Setting the Capture File in AmCap - Preallocating and Defragmenting.....	120
Capturing Video with AmCap	121
DirectXMedia Details	122
Information Specific to Windows 2000 or Windows XP	123
Information Specific to Windows NT	123
General Information	123
Cropping and Scaling	124
Ligos Technology Indeo	124
Control Panel	126
Video Input	126
Video Format.....	126
Video Adjustments	127
Board Select.....	127

Chapter 9 - Troubleshooting 129

Blue/Pink/Black/Orange Video Screen	129
Black Preview Video Screen	130
Scrambled Video Image.....	130
Grainy, Dithered Image	130
Slow Overlay Drawing	130
Problems using Direct Draw	131
Poor Video Quality at Large Frame Sizes.....	131

Wrong Capture Driver Being Accessed	131
Unwanted Closed Caption Text	132
No Closed Captions on DV or PAL Video	132
Interrupt Conflicts.....	132
Conflicts Between PCI Cards.....	133
Conflicts of PCI Cards with ISA Cards	133
Multiple Horizontal Lines Across Video Image	134
Cannot Play Back Audio Recorded by the Osprey-540 Card	134
Video Control Dialog Windows are Empty under WinNT.....	135
Appendix A - Hardware Specifications	137
Appendix B - Color Modes	139
YUV Format Details	139
Appendix C - Video Sizes	141
Appendix D - Using the Osprey Video Capture Driver with Other Drivers.....	143
Appendix E - Direct Draw.....	145
Appendix F - Multiboard Installations.....	147
The Recommended Multi-Board Selection Approach	147
The Legacy Multi-Board Selection Approach	148
Appendix G - File and Registry Usage	149
Instructions for Windows NT 4.0	150
Instructions for Windows 2000 and Windows XP	152
Appendix H - Adding/Moving Boards in Windows 2000 and Windows XP.....	155
Instructions for Windows 2000	155
Instructions for Windows XP.....	156
Appendix I - Developer Support	161

Chapter 1 - Getting to Know the Osprey-540 Capture Card

The Osprey-540 Capture Driver User's Guide provides practical information for installing and configuring the hardware and software for Osprey-540 device. This guide has been designed with the needs of the end user in mind, particularly first-timers and those working with existing applications.

Symbols

Introduction

Features

Software Included

Compatible Third-Party Applications

Getting Help

Symbols



This symbol denotes an important note or warning.



This shortcut icon points more experienced users to sections or chapters that summarize step-by-step instructions.



This symbol denotes additional information.

Introduction

The Osprey-540 is a single-slot PCI card that delivers uncompressed digital video and audio in real time to media applications. The variety of video and audio inputs supported by the Osprey-540 allows it to meet quality demands across a wide spectrum of professional and prosumer users.

The Osprey-540 builds on many of the award winning Osprey-500 features and benefits bringing you a capture device designed for the media professional. Going beyond the Osprey-500 series, the Osprey-540 offers several unique features catered to the professional media content creator including the addition of embedded SDI audio support and analog audio clocks locked to any of the video sources.

Features

The Osprey-540 can provide to host applications audio and video from any of the following sources:

- ◆ Decompressed DV video and audio from IEEE-1394 DV devices
- ◆ Digital Video and Audio from SDI (SMPTE-295M) sources
- ◆ Video from S-video/Composite sources
- ◆ Digital AES/EBU Audio from digital audio sources
- ◆ Audio from Balanced or Unbalanced analog sources

The Osprey-540 also offers the following features:

- ◆ Video Cropping
- ◆ Video Scaling
- ◆ Video Color Conversion or Reformatting
- ◆ Video Software De-interlacing
- ◆ Video Logo/Bitmap Overlay
- ◆ Closed Captioning for Analog and SDI sources
- ◆ Hardware Audio Gain/Attenuation for Analog inputs
- ◆ Analog audio locked to selected video source
- ◆ Analog audio/video monitoring of selected video input source
- ◆ SimulStream Capable

The Osprey-540 enables real-time streaming from a digital video (DV) source. The Osprey-540 *actually decodes DV video on the card*, optionally scales and color converts the resultant digital video, and transfers the digital video directly to the host. The host CPU can then be used to encode the data for streaming. This is far superior to most IEEE-1394 DV solutions that capture DV data to the host. In these systems, the host CPU must first decode, scale, possibly color convert, and reformat the data before it can encode it for streaming. Decoding on the Osprey card leaves the bulk of your CPU power for creating higher-quality video streams.

The Osprey-540 also captures digital video and audio in the formats produced by professional-level camera and production equipment, including SDI video with embedded audio, and professional digital audio (AES/EBU). Like analog and DV video sources, the Osprey-540 can further scale, crop, etc the SDI video being captured in order to provide the video in the most optimal format for further host based processing.

Bitmap overlays make it easy for users to superimpose images such as company logos over the video stream while video is being captured. MMX accelerated de-interlacing removes interlacing artifacts in interlaced video making the video easier and more efficient to encode and thus produces higher quality streaming video.

Line-21 closed caption support is now provided for both analog and SDI inputs. Closed caption data can be overlaid onto the video being captured as well as provided as a separate stream. As a separate but synchronized text stream, closed caption data streams can be streamed along with audio and video.

With the addition of locking the analog audio clocks to any of the video sources the Osprey-540 provides new levels of synchronized/locked audio and video capture. Mixing digital video and analog audio sources produces no drift between the time bases of the sources.

The selected audio and video input for capture is also redirected to the analog outputs on the Osprey-540. These outputs include unbalanced audio and svideo and composite video.

Digital SimulStream is an added-cost software product available for the Osprey-540. With SimulStream any number of applications can access data being captured by a single board. A single board can feed multiple encoding applications even if each requires a different audio or video profile. Please see the SimulStreaming User's Guide which is installed in the Osprey-540 Program group for details about this feature.

Audio/Video Specifications

Video Frame Rates and Performance

Audio/Video Specifications

Video Input

Audio Input

Video/Audio Output

Audio Processing

Hardware Video Processing

Computing Platforms

Hardware System

Video Input

- ◆ NTSC/PAL
- ◆ Composite (RCA-style)
- ◆ S-Video (Mini-DIN style)
- ◆ DV (via 4pin IEEE-1394 connector)
- ◆ SDI (SMPTE-259M) (BNC style)

Audio Input

- ◆ Unbalanced stereo (RCA connectors)
- ◆ Balanced stereo (XLR connectors)
- ◆ SDI (SMPTE-259M)
- ◆ Professional digital audio AES/EBU (XLR connector)
- ◆ DV Audio (via same IEEE-1394 connector as DV Video)

Video/Audio Output

The video and audio inputs can be monitored via the connectors on the output breakout cable. The cable includes connectors for:

Video Outputs

- ◆ Composite (BNC)
- ◆ S-Video (mini-DIN)

Audio Outputs

- ◆ Unbalanced audio (two RCA connectors).

Audio Processing

- ◆ Auto sample rate selection for analog inputs (32 kHz/44.1 kHz/48 kHz)
- ◆ Audio sample rate down conversion based on application requirements
- ◆ Audio sample rate up conversion based on application requirements
- ◆ Gain and Attenuation can be controlled in hardware for analog inputs. For digital inputs a software gain or attenuation can be applied.

Hardware Video Processing

- ◆ **DV decoding** in hardware produces a decompressed video and uncompressed audio stream that can be captured.
- ◆ **Scaling** can be applied in hardware to any video source before capture.
- ◆ **Color space conversion** can be applied in hardware before video is captured to the host. Supported color formats are:
 - ◆ RGB (32/24/16/15)
 - ◆ YUV (4:2:2 packed or planar YVU9/YUV12)
 - ◆ Grayscale (Y)
- ◆ **Cropping** can be applied in hardware to any video source before capture.

- ◆ **Brightness/Contrast/Saturation/Hue** adjustments can be applied to the analog inputs prior to capture (hue not applicable to PAL signals). For digital inputs, only the first three can be adjusted. **Bypass color correction** is available for digital inputs that allows for the digital inputs to not have any correction applied. This is the recommended mode for digital inputs.

Computing Platforms

- ◆ Windows 2000 Professional
- ◆ Windows XP
- ◆ Windows NT 4.0

Hardware System

- ◆ 32-bit/5-volt PCI card
- ◆ Full PCI Rev. 2.2 compliance
- ◆ Multi-board support

Video Frame Rates and Performance

The Osprey-540 can deliver to the host 30 frames per second (fps) full resolution NTSC (720x480) as well as 25 fps full resolution PAL (720x576). The Osprey-540 uses Direct Memory Access (DMA) to efficiently perform this delivery of both video and audio data to the host. Once the data is in host memory, performance is directly affected by how the data is processed. The Osprey-540 also supports DirectDraw for displaying video with minimal load on the system processor.



It should be noted that uncompressed video bandwidth is very large. Video at 640x480 with a 16bit color format at 30fps results in more than 18Mbytes/sec of data transfer across the PCI bus. Thus PCI bandwidth issues, which may result due to other high bandwidth demanding devices on the PCI bus, can limit performance.

For example, having PCI based SCSI controllers may consume large amounts of PCI bandwidth if lots of SCSI disk activity is occurring.

Software Included

The products for Windows XP, Windows 2000, and Windows NT 4.0 include:

- ◆ A Video for Windows compatible video capture driver capable of being upgraded to SimulStream
- ◆ An audio Mixer and an audio Wave driver
- ◆ VidCap32 - a simple video capture application allowing for capturing and viewing the various video features of the device
- ◆ A variety of other software applications (Windows Media encoder, Windows Media Player, RealProducer, RealPlayer, etc.). Note that these are only available on the CD-ROM and not on the web-based software release.

Compatible Third-Party Applications

Any VFW or DShow based audio/video application should be compatible with the Osprey-540. If you find an application that does not appear to be compatible see the getting help section before contacting our support group.

Getting Help

Before contacting support, please do the following:

- ◆ Work through the section of Chapter 3 entitled **Testing the Installation for Windows 2000**, Chapter 4 entitled **Testing the Installation for Windows XP**, or Chapter 5 entitled **Testing the Installation for Windows NT**.
- ◆ Read through **Chapter 9 - Troubleshooting**.
- ◆ Visit our web site at <http://www.viewcast.com/> and read the Osprey-540 FAQs by selecting **Support > Osprey Product Line > FAQs**.

If you have done that and you're still having problems, contact the Osprey Support Group at:

Voice, toll free	(888) 684-6622
Voice	(919) 319-9200
Fax	(919) 319-9814
E-mail	mailto:support@ospreyvideo.com

When you contact support, especially if it is by email, please include the following information:

- ◆ Which operating system you are using. Certain minor aspects of the Osprey-540 drivers are different between Windows XP, Windows 2000, and Windows NT 4.
- ◆ Which version of the Osprey-540 driver you are using. The version information is on the title bar of the driver's Control Dialog, as well as in the first message of the installation program.
- ◆ The type of audio and video source being used (for example: PAL SDI video and AES/EBU audio) and the type of equipment being used as the source (for example: a Sony A500 Digital Betacam Deck).
- ◆ Any additional details about your system configuration would be helpful – for example, the system speed, processor type, motherboard chipset, whether you have a SCSI or IDE hard drive, whether you have a network adapter card, and the type of display adapter card.
- ◆ A detailed description of the problem.

Chapter 2 - Osprey-540 Hardware

The Osprey-540 Capture Cards are 32-bit, 5-Volt cards. They are compliant with version 2.2 of the PCI hardware specification. The DV option of the Osprey-540 is a daughter card. Thus the Osprey-540 is actually composed of 2 cards. Below is a picture of the Osprey-540 (actual hardware may differ in minor ways):

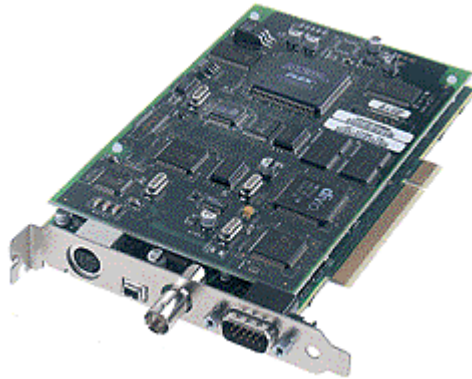

System Requirements

Configuring the Video Capture Driver

Installing the Card

Connecting Cables

System Requirements

For x86 PCs, the minimum system requirements are as follows:

- ◆ 90 MHz Pentium processor or higher for the hardware. Microsoft currently recommends a Pentium PIII 700 Xeon or better with 128Mb RAM running Windows 2000 or Windows XP for running the Windows Media Encoder 7.
- ◆ One available PCI slot
- ◆ Windows NT 4.0, Windows 2000, or Windows XP
- ◆ Approximately 7.5 megabyte of storage for system files

For optimum performance, we recommend at least the following additional features.

Video display adapter with:

- ◆ 2MBytes memory minimum (4 Mbytes or more recommended)
- ◆ Direct Draw capability
- ◆ An up-to-date display device driver with Direct Draw capability



With the Osprey-540 you can use on-board audio capture capability to capture sound and multiple cards to capture multiple audio streams. However, you still need a sound card to play back audio since the Osprey-540 is only a capture device and not an audio playback device. The Osprey-540 will only provide audio-out useful for monitoring the audio input, not for playback purposes.

Configuring the Video Capture Driver

Use the video capture application VidCap32 to access the Osprey driver Control Dialog described in [Chapter 6 - Osprey-540 Video Control Dialog](#).

VidCap32 is included with the Osprey package. It is useful for testing the installation and for general purpose viewing of video. Refer to [Chapter 8 - VidCap32](#) for instructions on using this applet.

Installing the Card

All computer cards are sensitive to electrostatic discharge. Slight discharges from clothing or even from the normal work environment can adversely affect these cards. By following these simple guidelines, however, you can minimize the chance of damaging your Osprey card.

To be used only with UL Listed computers that include instructions for user installed accessories.



- ◆ Handle cards only by the non-conducting edges.
- ◆ Do not touch the card components or any other metal parts.
- ◆ Wear a grounding strap while handling the cards (especially when located in a high static area).
- ◆ Provide a continuous ground path by leaving the power cord plugged into a grounded power outlet.

Ensure that the workstation is powered OFF before installing any components.



If you are not familiar with how to install a PCI bus card, refer to your system's documentation for more complete, step-by-step instructions.

You should install the Osprey card before installing the software driver. However, with Windows 2000 or Windows XP you also have the option to pre-install the software before installing the hardware.

Use the following steps to install the Osprey card:

1. Power down the computer. Make sure that the computer's power switch is turned OFF. Read caution note above for grounding precautions.
2. Remove the computer's cover.
3. Locate an empty PCI slot.
4. Remove the slot-cover screw from the empty PCI slot's cover, set the screw aside, and remove the slot cover.
5. Remove the card from its anti-static bag.
6. Install the Osprey card into the empty slot and make sure that it is seated evenly in the slot.
7. Secure the backpanel of the card with the slot's cover screw.
8. Replace the computer cover.
9. Connect video and audio cables to the Osprey card. Refer to [Connecting Cables](#) for details of the card's backpanel connector.
10. Turn the computer on.

Connecting Cables

[Connecting a Composite Source](#)

[Connecting an S-Video Source](#)

[Connecting an SDI Source for the Osprey-540](#)

[Connecting an IEEE-1394 Source for the Osprey-540](#)

[Connecting Audio Source with the Osprey-540](#)

The Osprey-540 board has four connectors on the back plate for audio and video:

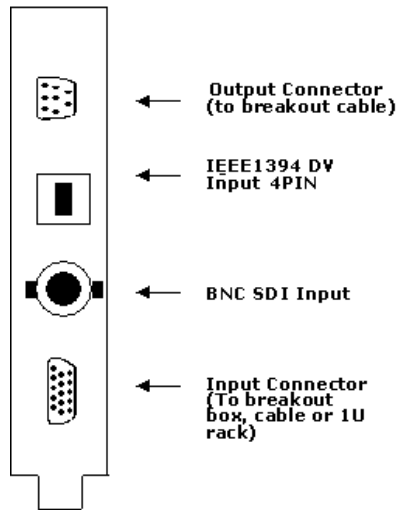

Osprey-540 Input Breakout Cable

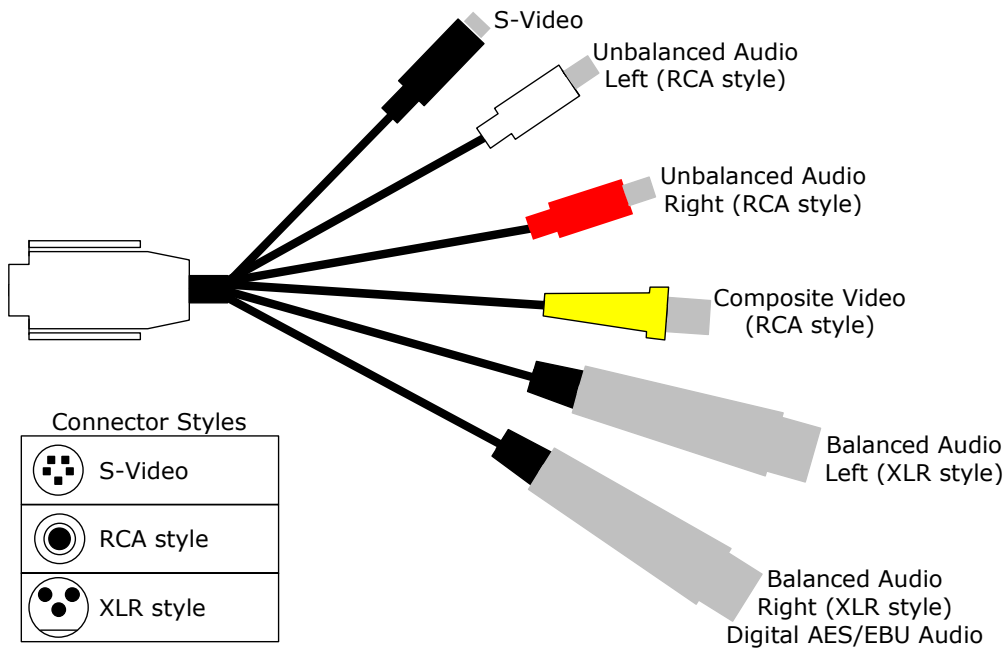

The breakout connector has inputs for composite video, S-Video, balanced and unbalanced audio, and professional digital audio. The breakout cable has a set (L/R) of unbalanced RCA style audio connectors and a set (L/R) of balanced (XLR) audio connectors. Additionally, the right XLR balanced input also is used as the professional digital audio input.



The input breakout cable is ViewCast Part Number 34-05009-01.

Osprey-540 Output Breakout Cable

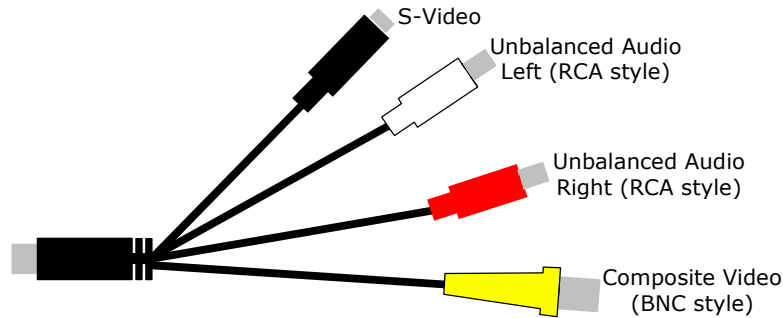

The output breakout cable has a set (L/R) of unbalanced RCA style audio connectors, a S-video connector, and a BNC style video connector.



The output breakout cable is ViewCast Part Number 34-05008-01.

Rack-mount Panel

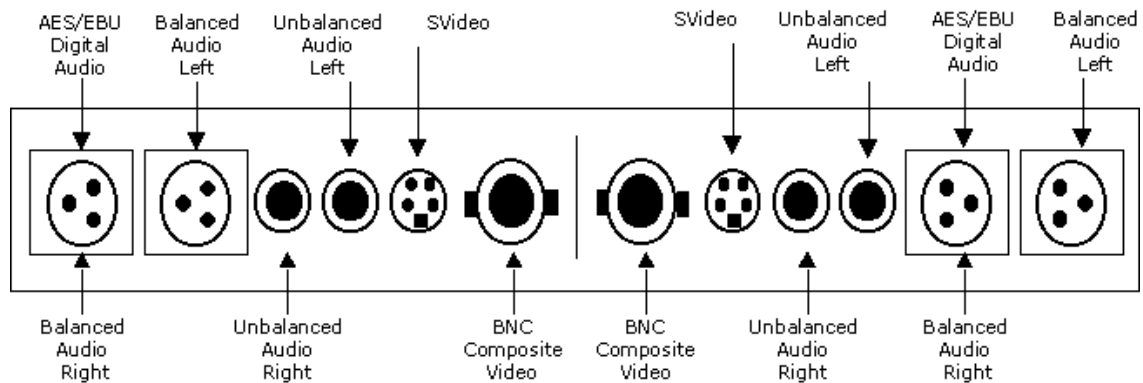

A rack mount version of the breakout input cable is also available. The 1 unit high rack mount input panel has the same inputs as the cable but includes two sets of inputs. However, the composite video connection on the rack mount panel is a BNC style connector. Thus a single rack mount input unit provides for two Osprey-540 cards. The rack mount unit is pictured above.



The rack-mount breakout box is ViewCast Part Number 95-00151-02.



Exact connector layouts are subject to change.

Connecting a Composite Source

If your video source provides only composite video, connect the source's output cable to the Composite Video In connector. This is a RCA-style connector on the breakout cable. On the rack-mount panel, the composite video connection is a BNC connector.

A BNC to RCA adapter is provided if you don't have a BNC composite cable.

Connecting an S-Video Source

If your video source supports S-Video, connect the source's output cable to the S-Video In connector on the breakout cable. Compared to composite signals, S-Video provides a sharper image with better color separation. S-Video uses a four-pin mini-DIN connector that provides separate Y (luminance) and C (chrominance) signals. Refer to [Chapter 6 - Osprey-540 Video Control Dialog](#) for instructions on configuring the driver for S-Video.

Connecting an SDI Source for the Osprey-540

The Osprey-540 has a BNC connector for SDI (SMPTE-259M) video. A high quality SDI-qualified cable should be used when utilizing this connection, especially when the cable length is long. SDI carries both digital video and embedded digital audio, and the Osprey-540 can capture both.

Connecting an IEEE-1394 Source for the Osprey-540

The Osprey-540 has a DV input. DV carries digital audio and video and both can be independently used by the Osprey-540. The DV input is a 4 pin IEEE-1394 connection.

Connecting Audio with the Osprey-540

The Osprey-540 has a variety of audio inputs, both analog and digital. The typical consumer will probably find the unbalanced analog RCA audio inputs to be the most useful. Balanced audio inputs (via XLR connectors) provide cleaner audio especially if the cable length is very long. The prosumer may have a DV camera source and may choose to use the audio embedded in the IEEE-1394 DV stream. The professional or broadcast user may choose to use the digital audio embedded in the SDI (SMPTE-295m) signal. The breakout cable contains a single professional AES/EBU stereo digital audio input. This input is shared with the right balanced analog input to prevent having both balanced audio and professional digital audio connected at the same time.

The selection of audio input to capture is independent of the video input selection. For example, even if you choose to use DV video as a source, you can still opt to use the analog balanced inputs instead of audio embedded in the DV stream.

Chapter 3 - Installing the Software - Windows 2000

The Windows NT 4.0 Osprey drivers do not work with Windows 2000. If your Osprey card(s) were installed under the Windows NT 4.0 operating system and the PC has now been upgraded to Windows 2000, you need to install the Windows 2000 drivers.

Please note:



- ◆ Administrative privileges are required for installation.
- ◆ Before installing software, check the ViewCast.com support website or the ftp site for the any driver update releases subsequent to the software shipped on your CD. For the ViewCast.com support website, go to <http://www.ospreyvideo.com/> > **Downloads** > **Software & Drivers** > select Win2000 and Osprey-540 from the table. To reach the ViewCast.com ftp site, go to <ftp://ftp.viewcast.com/pub/OSP-540/win2000/latest>. It's a good idea to check these sites periodically for update releases.
- ◆ The screens used to illustrate the installation steps may not be exactly what displays on your computer screen. In some cases, version numbers and other minor differences may display in the installation you are running.

Basics: Installing From CD

Basics: Downloading and Installing Updated Drivers

Canceling Out of the Found New Hardware Wizard

Two Install Scenarios

Scenario 1: Osprey Card(s) not Physically Installed in the PC

Scenario 2: Osprey Card(s) Physically Installed, but Osprey Software not Installed

Testing the Installation

Uninstalling the Software

Basics: Installing From CD

If necessary, follow the directions in [Chapter 2 - Osprey-540 Hardware](#) to install the Osprey card. This software installation procedure works properly only if the card is already installed.

1. Turn on the machine and start Windows 2000.
2. **Cancel** out of the *Found New Hardware* wizard.
3. If you are updating from a previous version of the driver, it is necessary to uninstall the old driver before installing the new driver. Please refer to [Uninstalling the Software](#) for instructions.
4. Insert the Osprey-540 Driver CD into your CDROM drive. The installation instructions assume this is the (D:) drive. Substitute the proper drive as it is configured on your system, if necessary.
5. Run the installation program
 - a. Click the **Start** button
 - b. Click **Run**
 - c. Enter **D:\Win2000\Setup** in the dialog box
 - d. Click **OK**
6. The installation program steps are self-explanatory for many users. If you need additional information, please refer to the section entitled [Option A: Run the Installation Program \(Recommended\)](#).
7. The driver and demo program are ready for use as soon as the installation program completes and you have rebooted the system. We suggest that you test the driver immediately. Please refer to [Testing the Installation for Windows 2000](#).

Basics: Downloading and Installing Updated Drivers

1. The latest software drivers for Osprey-540 Capture Cards are available via FTP (file transfer protocol) at the following locations:

<ftp://ftp.viewcast.com/pub/OSP-540/win2000/latest>

There are also links to the drivers from our web site at

<http://www.ospreyvideo.com>.

2. It is necessary to uninstall your existing Osprey-540 driver before installing a newer version of the driver. Follow the instructions in [Uninstalling the Software](#) and restart your computer before beginning the new install procedure.

3. Use your web browser, such as Microsoft Internet Explorer or Netscape Navigator, to find our FTP site and download the file. Type the FTP address shown above into the address box at the top of your browser window. You may find it simpler to type just the first part of the address - <ftp://ftp.viewcast.com/> - and then click on the list of directories that display until you reach the **win2000/latest** location. Refer to your browser's help files for more specific and detailed assistance.
4. Download the web package file in **win2000/latest** to your hard disk.
5. The *Found New Hardware* wizard displays detecting each Osprey-540 card in the computer. Follow the directions in Canceling Out of the Found New Hardware Wizard at each prompt.
6. Run the web package program:
 - a. Click the **Start** button.
 - b. Click **Run**.
 - c. Enter *<pathname>* in the dialog box, where *<pathname>* is the location and name of the file that you have downloaded.
 - d. Click **OK**.
 - e. The program prompts for a temporary location for unpacking the install files.
 - f. See Option A: Run the Installation Program (Recommended) for a full description of the Installation Program steps.



These files are not automatically deleted after setup has run. This feature exists to offer the option of performing the manual Plug and Play install later. If you want to conserve disk space, make a note of where these files are being unpacked, and delete them after the install.

Canceling Out of the Found New Hardware Wizard

When installing an updated Osprey-540 driver, first uninstall the existing driver and reboot the computer. The Found New Hardware wizard runs after rebooting. To cancel out the Found New Hardware wizard:

The Digital Signature Not Found window displays for the Osprey-540 video capture device.



1. Click **No**.

The Completing Found New Hardware wizard window displays.



2. Click **Finish**.

The Digital Signature Not Found window displays for the Osprey-540 audio capture device.



3. Click **No**.

The Completing Found New Hardware wizard window displays.



4. Click **Finish**.

Two Install Scenarios

There are two installation scenarios that might apply:

- ◆ **Scenario 1: Osprey Card(s) not Physically Installed in the PC**
- ◆ **Scenario 2: Osprey Card(s) Physically Installed, but Osprey Software not Installed**

In all cases, the most efficient and complete installation method is to run the **setup.exe** program on the product CD or in the web package that you downloaded. The setup program automates the Plug and Play steps required to install the drivers and ensures that they are performed correctly. It also installs the bundled applets and User's Guide. If you have multiple Osprey capture cards in the system, it configures all of the boards at the same time.



You can skip the detailed instructions if you are upgrading from one Osprey driver version to another. Just run the **setup.exe** file to install all the updated components.

Scenario 1: Osprey Card(s) not Physically Installed in the PC

This Pre-install Scenario is the method that we recommend if you are installing an Osprey card for the first time on a system and the Osprey software has not yet been installed. After the install is run and as soon as an Osprey card is installed in the PC, the card is detected and its drivers are started automatically.

Using Windows Explorer, locate and access the CD-ROM drive containing the Osprey Installation CD-ROM.

1. Navigate to the **WIN2000** directory.
2. Double-click **SETUP.EXE**.

The Osprey-540 Video and Audio Capture Driver window displays.

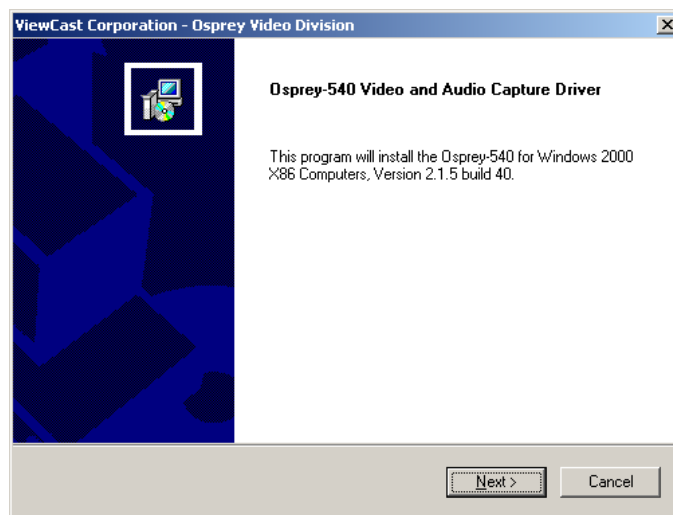

3. Click **Next**.

The Information window displays.

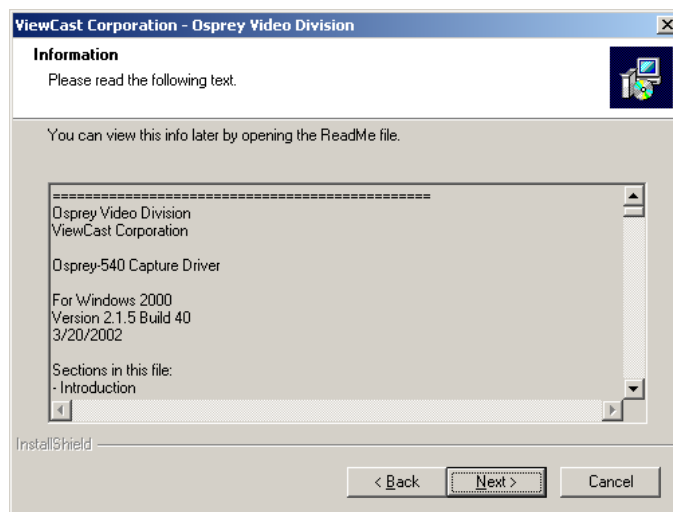

4. Click **Next**.

The Software License Agreement window displays.

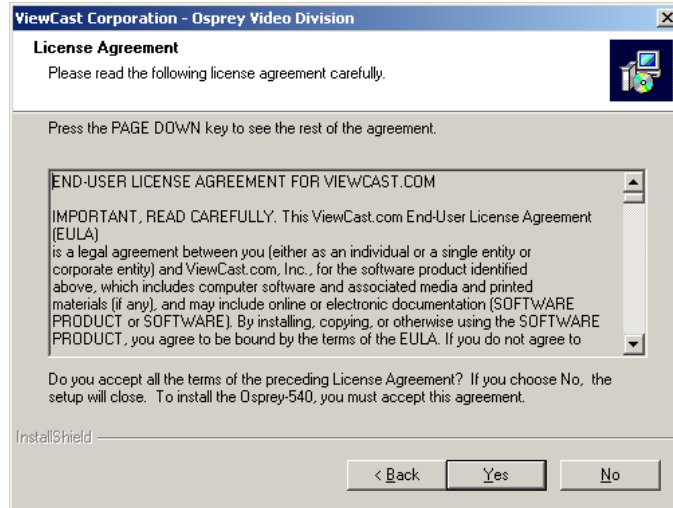

5. Click **Yes** to accept the End User Software License Agreement. If you do not wish to accept the agreement, click **No** to terminate the installation routine.

The Signal Type window displays.

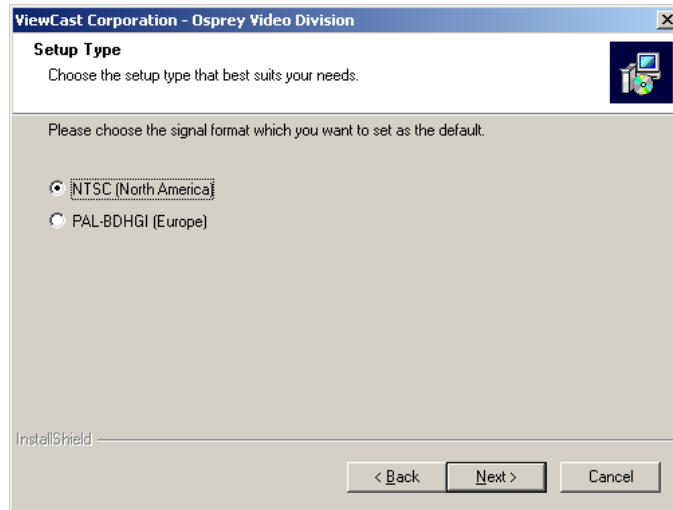

6. Click **Next**.
The Choose Destination Location window displays.

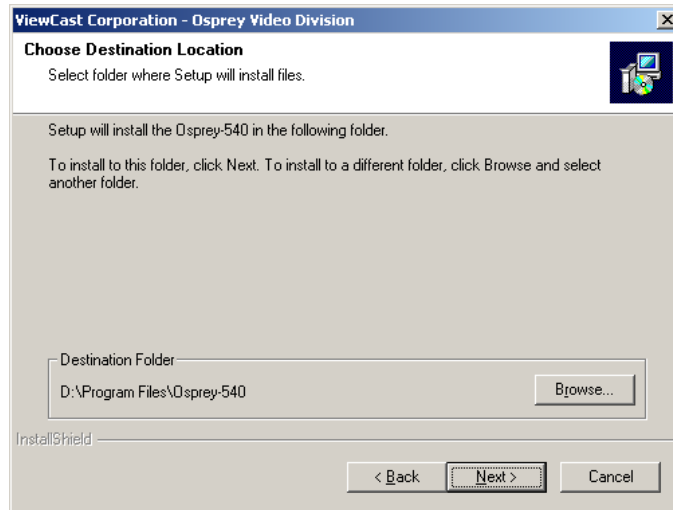

7. If you wish to change the destination location for the files, click **Browse**. Click **Next**.
The Select Program Folder window displays.

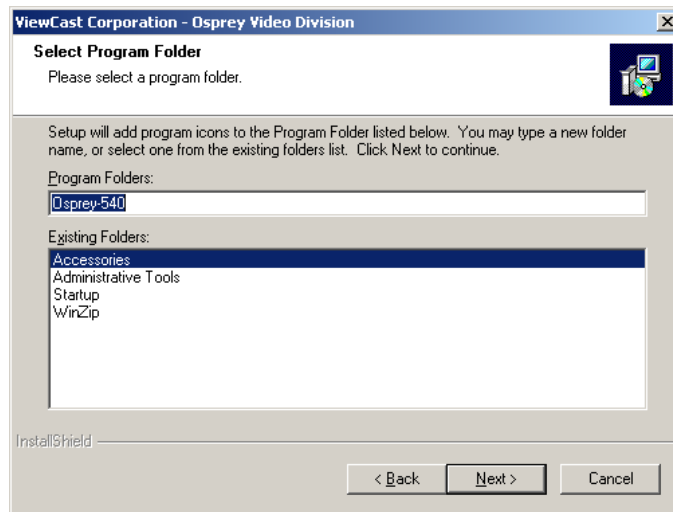

- If you wish to change the program folder, type the new name in the Program Folders field. Click **Next**.

The Start Copying Files window displays.

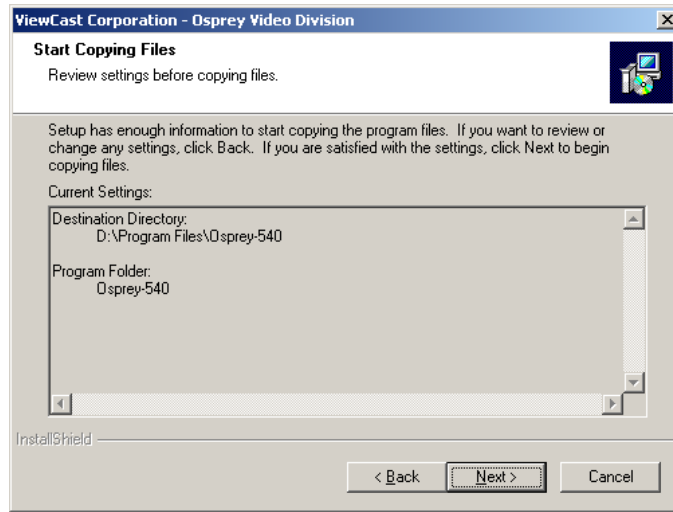

- If there are any settings to be changed prior to installation, click **Back** to return to the previous windows. Click **Next**.

A question dialog window displays.

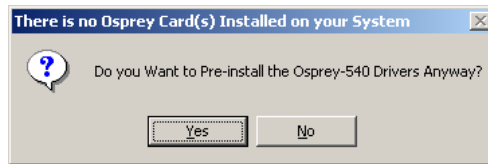

- Click **Yes** to continue the installation process.

The Osprey Video Division Offers Shortcuts window displays.



- Click **Yes** to place the shortcut on your desktop. If you do not want the shortcut on your desktop, click **No**.

A Question Dialog window displays.

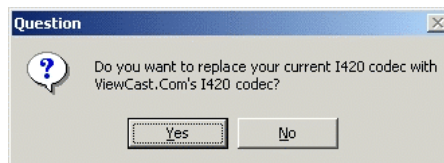

12. Click **Yes**.

The Setup Complete window displays.

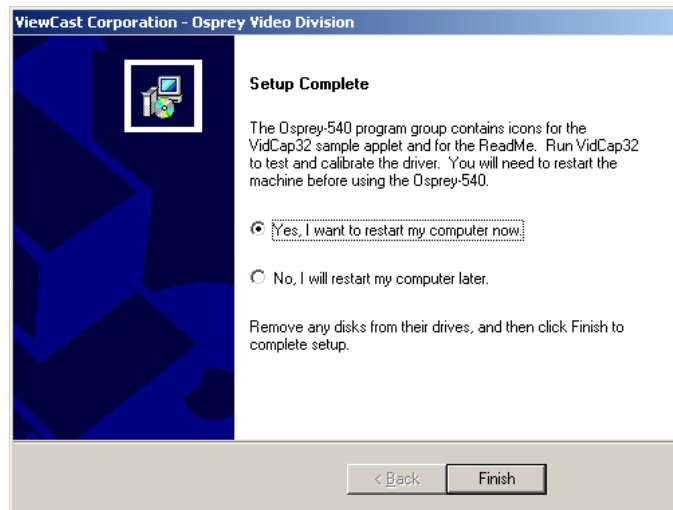

13. Click **Finish** to complete the installation.

If you are not installing the Osprey card at this time, click **No** then **Finish** to proceed. When you start your computer after installing the Osprey hardware, the **Found New Hardware Wizard** runs upon detecting new hardware. The sequence of windows are similar to that in [Appendix H - Adding/Moving Boards in Windows 2000](#).



The Osprey card does not need to be installed at this time. You also do not need to restart the computer at this time.

Scenario 2: Osprey Card(s) Physically Installed, but Osprey Software not Installed

In this case you have two options:

- ◆ **Option A: Run the Installation Program (Recommended)**
- ◆ **Option B: Use the New Hardware Found Wizard (Not Recommended)**

Option A: Run the Installation Program (Recommended)

When windows 2000 is started for the first time after the Osprey card is installed, the *Found New Hardware* wizard displays one or more times. After Windows 2000 has finished starting, cancel out of the **Found New Hardware Wizard**.

To install the Osprey drivers:

1. Using Windows Explorer, locate and access the CD-ROM drive containing the Osprey Installation CD-ROM.
2. Navigate to the **WIN2000** directory.
3. Double-click **SETUP.EXE**.

The Osprey-540 Video and Audio Capture Driver window displays.

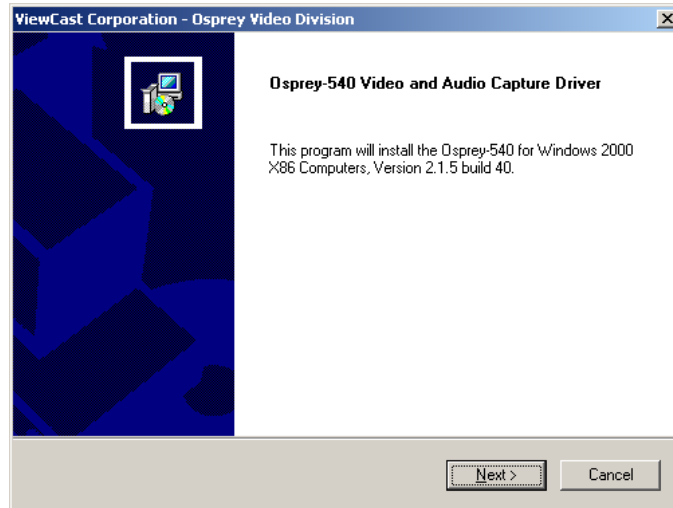

4. Click **Next**.

The Information window displays.

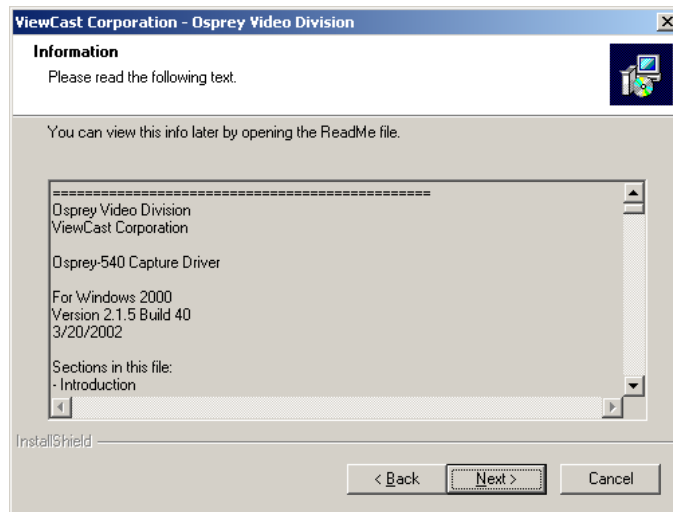

5. Click **Next**.

The Software License Agreement window displays.

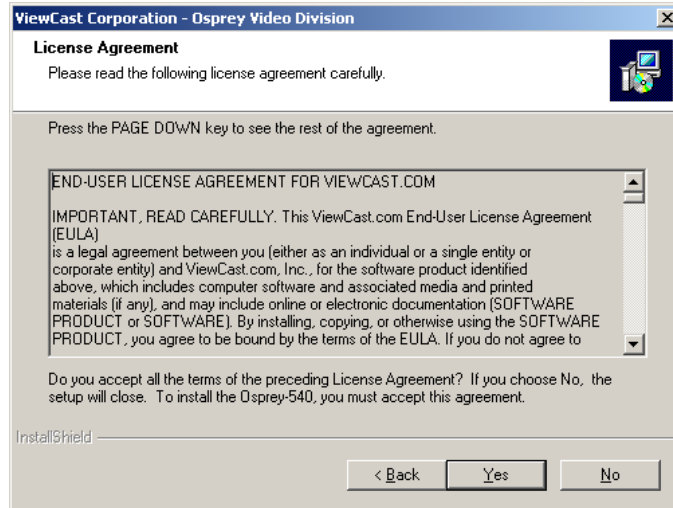

6. Click **Yes** to accept the End User Software License Agreement. If you do not wish to accept the agreement, click **No** to terminate the installation routine.

The Signal Type window displays.

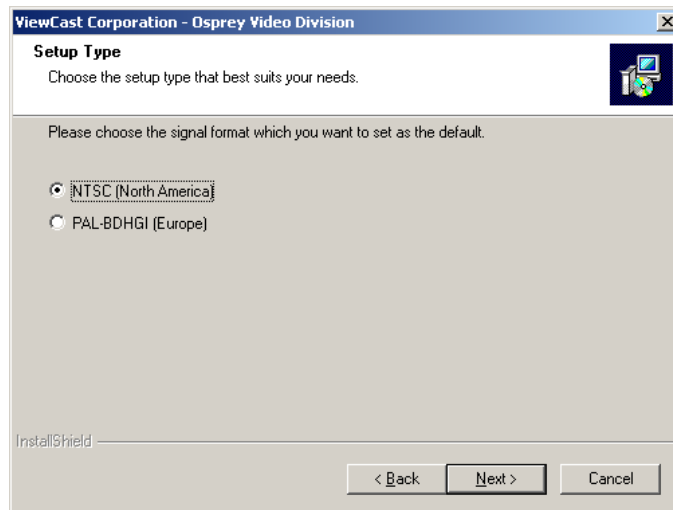

7. Click **Next**.
The Choose Destination Location window displays.

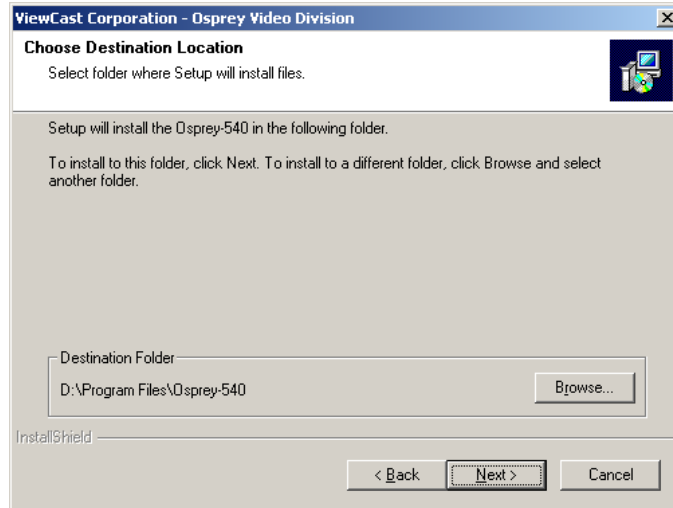

8. If you wish to change the destination location for the files, click **Browse**. Click **Next**.
The Select Program Folder window displays.

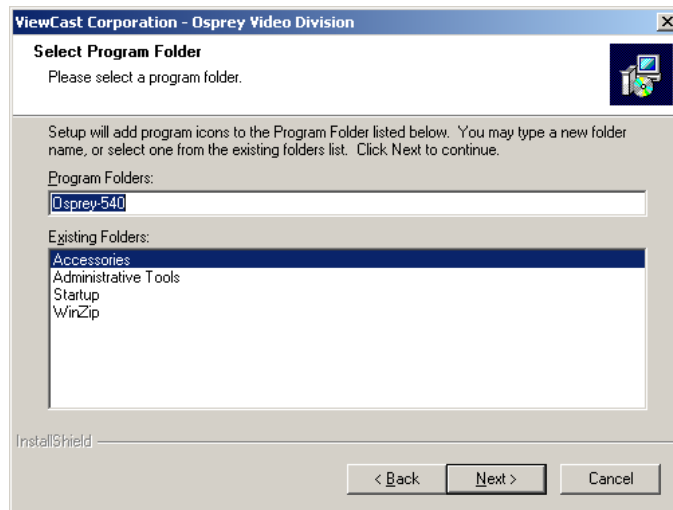

9. If you wish to change the program folder, type the new name in the Program Folders field. Click **Next**.

The Start Copying Files window displays.

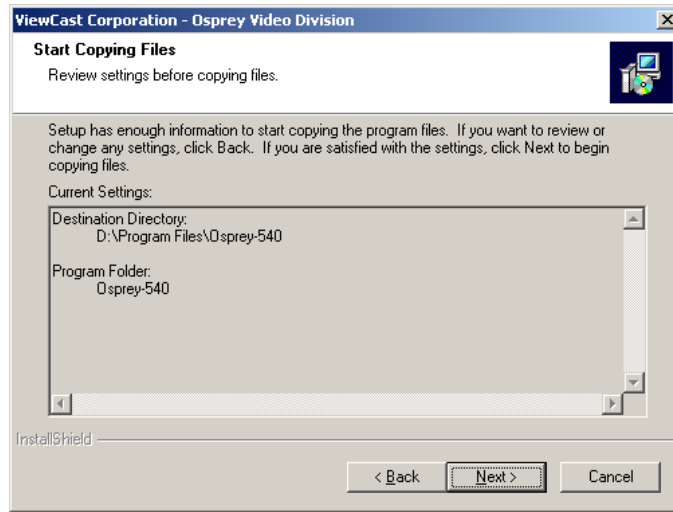

10. Click **Next**.

The Digital Signature Not Found window displays.

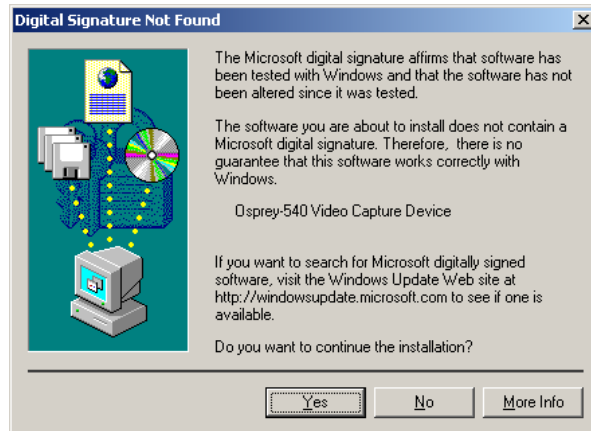

11. Click Yes.

The Digital Signature Not Found window displays.

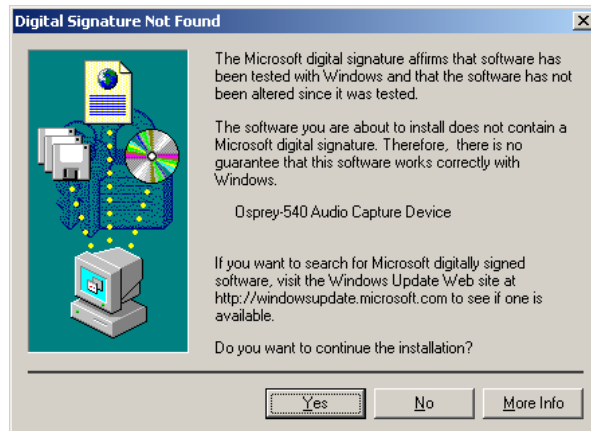

12. If there are any settings to be changed prior to installation, click **Back** to return to the previous windows. Click **Next**.
A question dialog window displays.

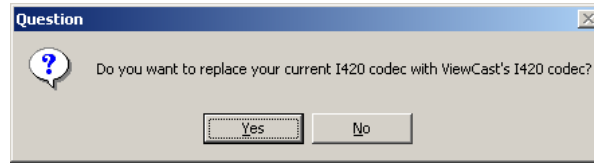

13. Click **Yes** to continue the installation process.
A question dialog window displays.

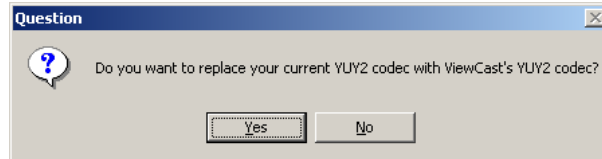

14. Click **Yes** to continue the installation process.
The Osprey Video Division Offers Shortcuts window displays.



15. Click **Yes** to place the shortcut on your desktop. If you do not want the shortcut on your desktop, click **No**.
The Setup Complete window displays.

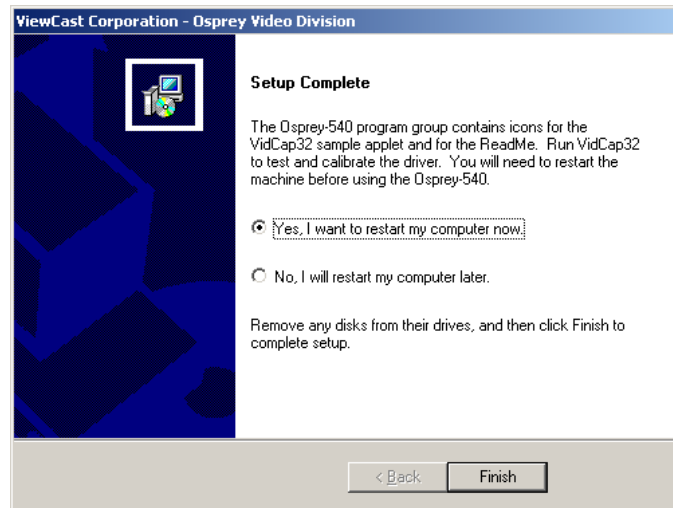

16. Click **Finish** to complete the installation and restart your computer. You must restart your computer before you can use the Osprey-540 card.

Option B: Use the Found New Hardware Wizard (Not Recommended)

This method is more complicated than Option A. It is particularly inconvenient if you are installing multiple cards at once, since each card has to be set up separately. This process installs only the driver and is useful only for updating the driver component. Furthermore, to get the sample applications and other required items, you must still run the setup.exe program detailed in Scenario 2, Option A.



The following windows and instructions assume that you are working with a computer on which the Osprey-540 software has never previously been installed.

When Windows 2000 starts, it detects the new card(s) and starts the Found New Hardware Wizard.



Please carefully note the terminology in the Found New Hardware Wizard.

For all Bt/Ct878-based Osprey cards, the Wizard detects two logical devices for each card - a *Multimedia Video Controller* device and a *Multimedia Controller* device.

The Multimedia Video Controller corresponds to the Osprey-540 video device. The Multimedia Controller corresponds to the Osprey-540 audio device.

The first window to display is the Found New Hardware Wizard.



1. Click **Next**.

The Install Hardware Device Drivers window displays.

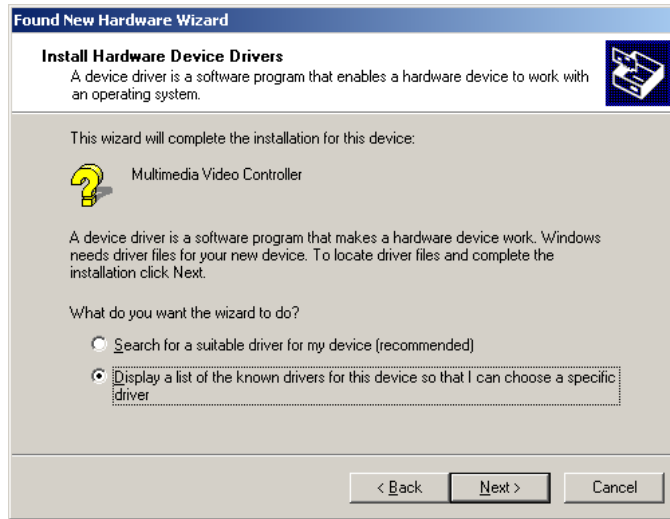

2. Click the **Display** option and click **Next** to continue.

The Hardware Type window displays.

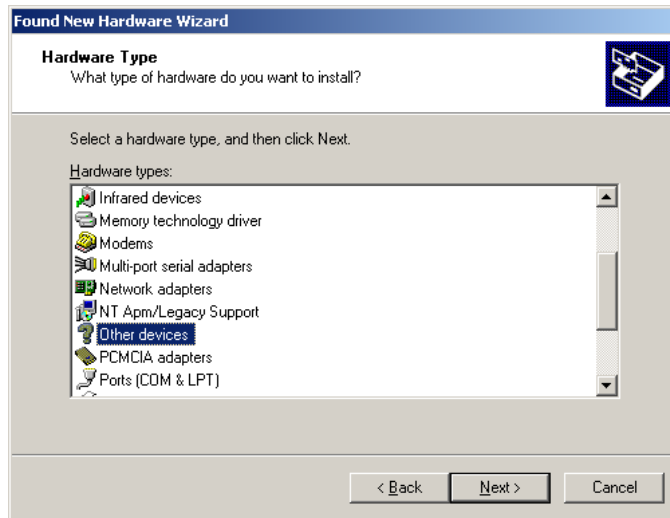

3. Scroll down to **Sound, video and game controllers**, click to select, then click **Next** to continue.

The Select a Device Driver window displays.

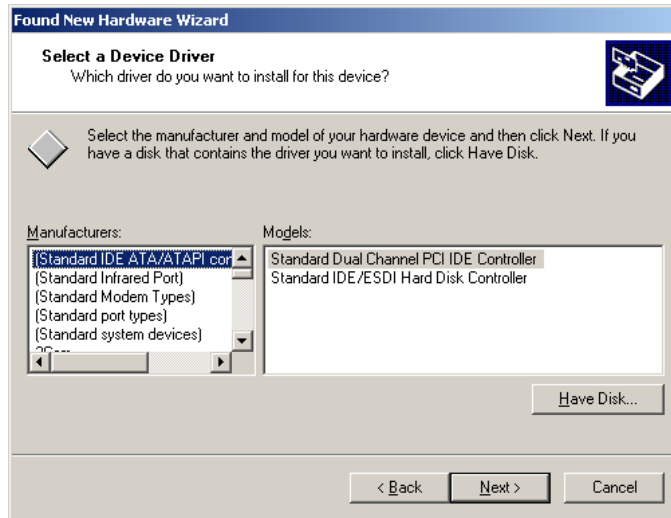

4. Click **Have Disk**.

The Install from Disk window displays.

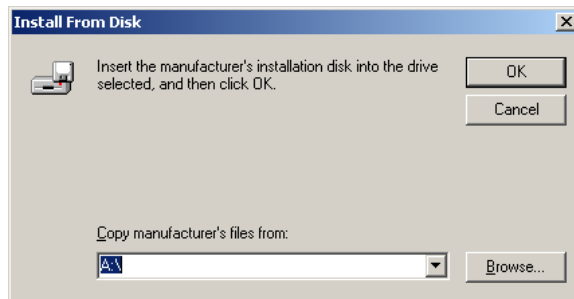

- The default path is usually A:\. Reset the path to the directory containing the Osprey-540 install files. In this example they are in E:\WINNT. Click **OK** once the path has been set.

The Select a Device Driver window displays.

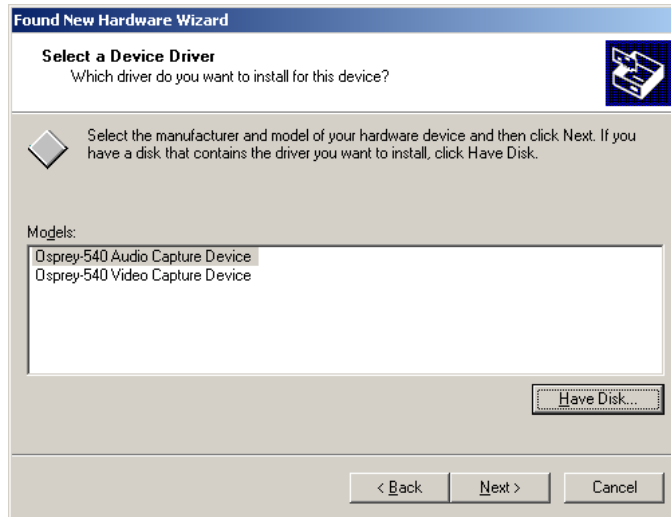

- Select the **Osprey-540 Video Capture Device** and click **Next**.
A warning message displays.

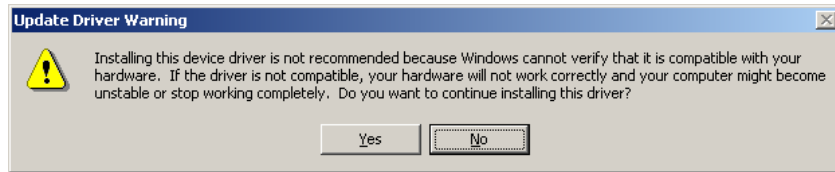

- Click **Yes**.

The Start Device Driver Installation window displays.

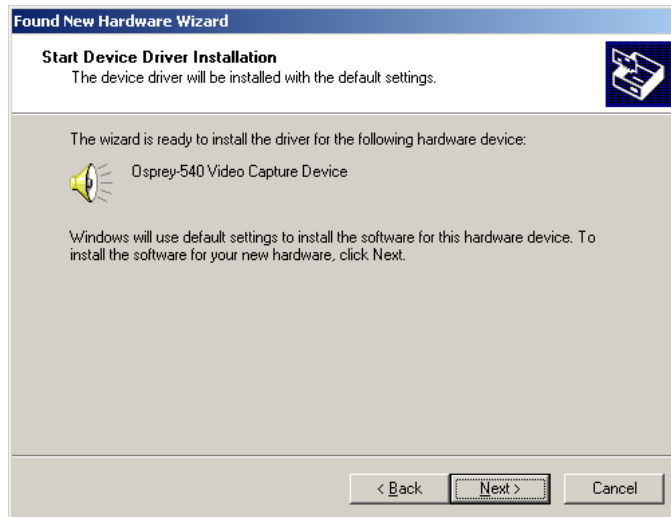

8. Click **Next**.

The Digital Signature Not Found window displays.

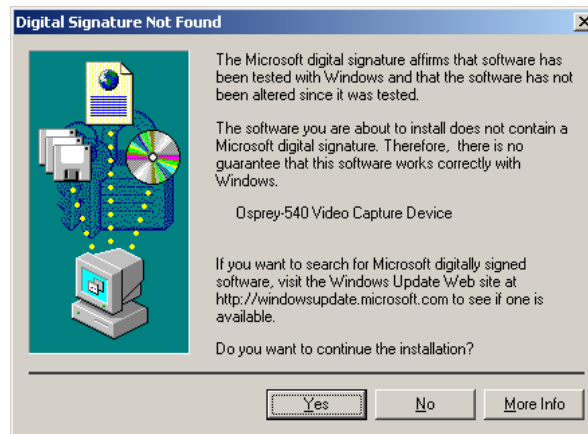

9. Click **Yes**.

The Completion window displays.



10. Click **Finish**.



At this point the **Osprey-540 video** driver has been installed. You should now get another *Found New Hardware* popup – this time for the Multimedia Controller (i.e., the **audio** device) - and a **new Digital Signature Message** for the Osprey-540 audio driver.

The second Found New Hardware Wizard window displays.

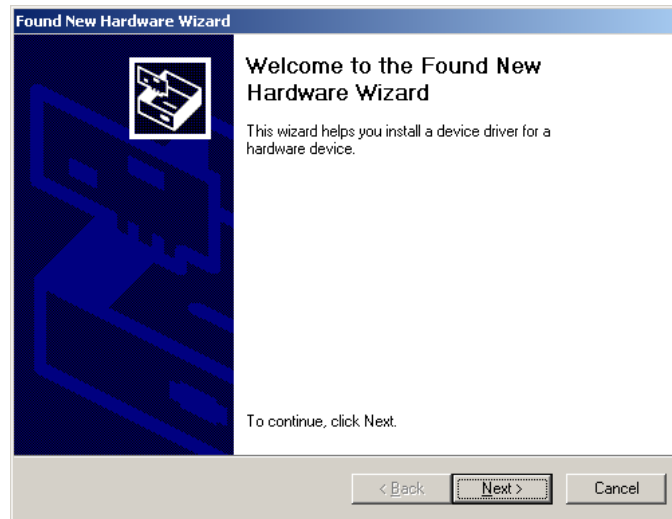

11. Click **Next**.

The Install Hardware Device Drivers window displays.

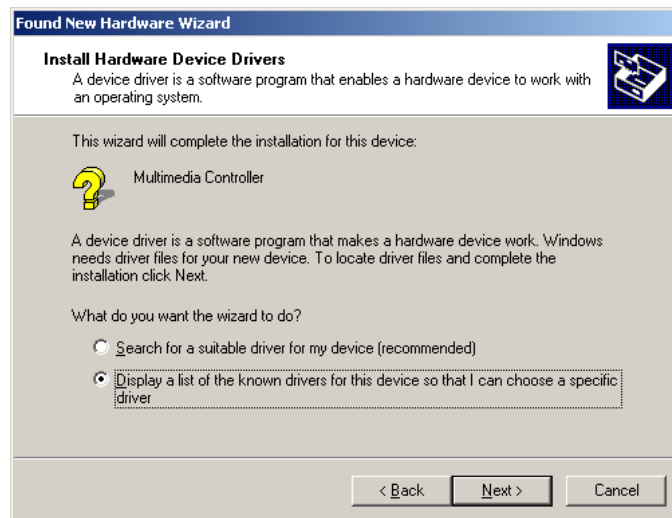

12. Click to select the **Display** radio button and click **Next**.
The second Digital Signature Not Found window displays.

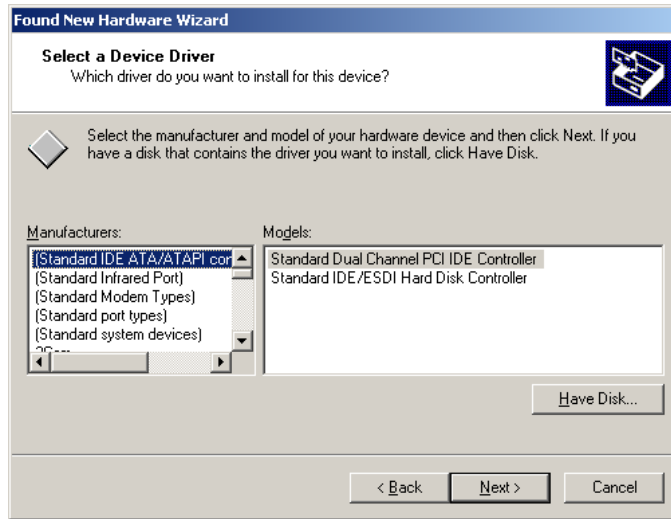

13. Click **Have Disk**.
The Install from Disk window displays.

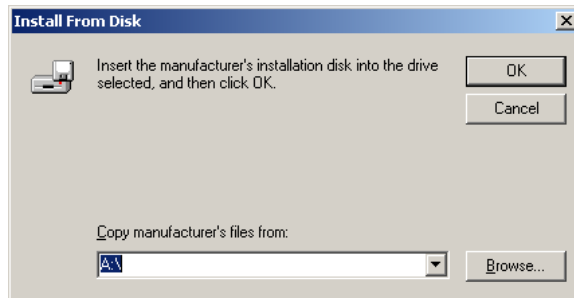

14. The default path is usually A:\. Reset the path to the directory containing the Osprey-540 install files. In this example they are in E:\WINNT. Click **OK** once the path has been set.
The Select a Device Driver window displays.

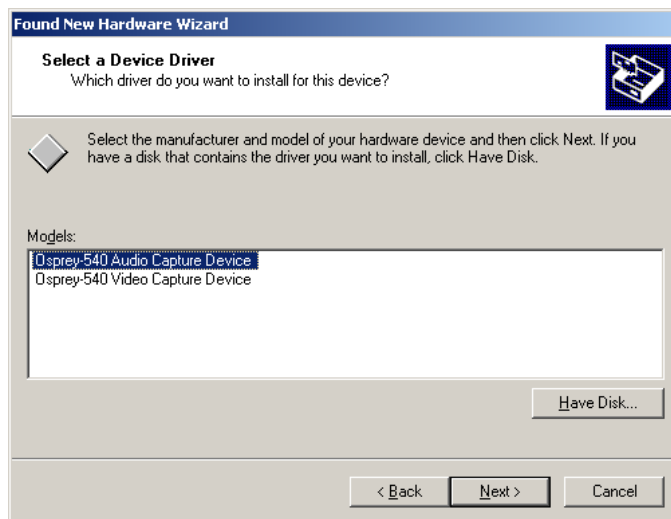

15. Click to select **Osprey-540 Audio Capture Device** and click **Next**.
A warning message displays.

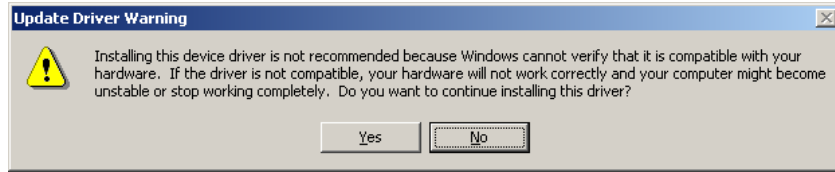

16. Click **Yes**.
The Start Device Driver Installation window displays.

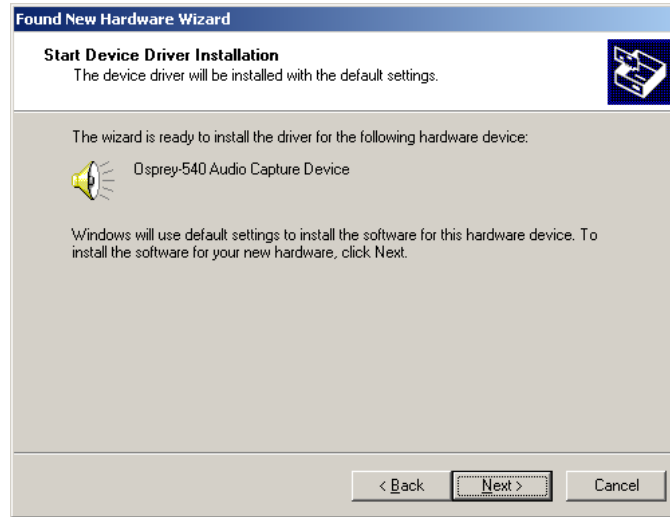

17. Click **Next**.
The Digital Signature Not Found window displays.



18. Click **Yes**.

The Completing the Found New Hardware Wizard window displays.

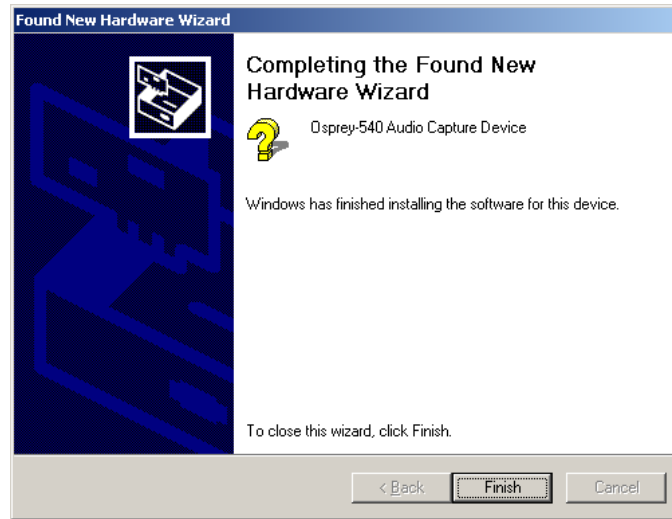

19. Click **Finish**.



This process installs only the driver and is useful only for updating the driver component. To get the sample applications and other required items, you must still run the setup.exe program. See Scenario 2, Option A for those instructions.

Indeo

Ligos Technology's Indeo codec is provided on the Osprey-540 CD. Double-click on file **Indeo\Disk1\Setup.exe** to install this package containing compression and color formats.

Please see **Ligos Technology's Indeo** in Chapter 10 - VidCap32, AmCap, and Included Demo Programs for a description of this package.

Testing the Installation for Windows 2000

1. Verify that the hardware installation is complete according to the directions in [Chapter 2 - Osprey-540 Hardware](#).
2. Connect a video signal source to one of the Osprey-540 connectors (Composite/S-video/SDI/DV).
3. Open the Osprey-540 group in the Start menu.
4. Click the **VidCap32** icon. Refer to [Chapter 8 - VidCap32](#) for more information on this application.
5. If your input is composite video, the screen displays a still video frame from the Osprey-540 board. Click the **Overlay** button. The screen should display moving video frames. If your input choice is not composite video, select the **Video Source** option under the **Options** menu. This brings up the Osprey-540's video capture driver configuration box where you can select your video input.
6. If the video area does not contain video, it could be for one of the following reasons:
 - a. The driver is looking for video on the wrong input connector. You can either move the video cable to another connector or reconfigure the driver using its Control Dialog. Refer to [Chapter 6 - Osprey-540 Video Control Dialog](#).
 - b. The video source is not turned on or activated.
7. If the video area is scrambled or has bad color, the signal format of your video source may be different from the signal format selected in the driver software. Since the driver defaults to NTSC-M signal format, users of PAL equipment always need to change the driver's signal format the first time they run the driver. Refer to [Chapter 6 - Osprey-540 Video Control Dialog](#) for more information.

Uninstalling the Software

If you need to remove the Osprey driver from your system:

1. Open the **Control Panel**.
2. Double-click **Add/Remove Programs**.
3. Click to select **Change or Remove Programs**.
4. Highlight the **Osprey-540 Driver** entry.
5. Click **Change/Remove** in the Osprey entry.
The uninstall program begins.
6. Click **Yes** to proceed.
7. Click **OK** when the process is complete.
8. Please reboot your computer to finish removing the driver.

Chapter 4 – Installing the Software – Windows XP

The Windows NT 4.0 Osprey drivers do not work with Windows XP. If your Osprey card(s) were installed under the Windows NT 4.0 operating system and the PC has now been upgraded to Windows XP, you need to install the Windows XP drivers.

Please note:



- ◆ Administrative privileges are required for installation.
- ◆ Before installing software, check the ViewCast.com support website or the ftp site for the any driver update releases subsequent to the software shipped on your CD. For the ViewCast.com support website, go to <http://www.ospreyvideo.com/> > **Downloads** > **Software & Drivers** > select WinXP and Osprey-540 from the table. To reach the ViewCast.com ftp site, go to <ftp://ftp.viewcast.com/pub/OSP-540/winXP/latest>. It's a good idea to check these sites periodically for update releases.
- ◆ The screens used to illustrate the installation steps may not be exactly what displays on your computer screen. In some cases, version numbers and other minor differences may display in the installation you are running.

Basics: Installing From CD

Basics: Downloading and Installing Updated Drivers

Canceling Out of the Found New Hardware Wizard

Two Install Scenarios

Scenario 1: Osprey Card(s) not Physically Installed in the PC

Scenario 2: Osprey Card(s) Physically Installed, but Osprey Software not Installed

Testing the Installation

Uninstalling the Software

Basics: Installing From CD

If necessary, follow the directions in [Chapter 2 - Osprey-540 Hardware](#) to install the Osprey card. This software installation procedure works properly only if the card is already installed.

1. Turn on the machine and start Windows XP.

2. **Cancel** out of the *Found New Hardware* wizard.
3. If you are updating from a previous version of the driver, it is necessary to uninstall the old driver before installing the new driver. Please refer to **Uninstalling the Software** for instructions.
4. Insert the Osprey-540 Driver CD into your CDROM drive. The installation instructions assume this is the (D:) drive. Substitute the proper drive as it is configured on your system, if necessary.
5. Run the installation program
 - a. Click the **Start** button
 - b. Click **Run**
 - c. Enter **D:\WinXP\Setup** in the dialog box
 - d. Click **OK**
6. The installation program steps are self-explanatory for many users. If you need additional information, please refer to the section entitled **Option A: Run the Installation Program (Recommended)**.
7. The driver and demo program are ready for use as soon as the installation program completes and you have rebooted the system. We suggest that you test the driver immediately. Please refer to **Testing the Installation for Windows XP**.

Basics: Downloading and Installing Updated Drivers

1. The latest software drivers for Osprey-540 Capture Cards are available via FTP (file transfer protocol) at the following locations:

<ftp://ftp.viewcast.com/pub/OSP-540/winXP/latest>

There are also links to the drivers from our web site at **<http://www.ospreyvideo.com>**.

2. It is necessary to uninstall your existing Osprey-540 driver before installing a newer version of the driver. Follow the instructions in Uninstalling the Software and restart your computer before beginning the new install procedure.
3. Use your web browser, such as Microsoft Internet Explorer or Netscape Navigator, to find our FTP site and download the file. Type the FTP address shown above into the address box at the top of your browser window. You may find it simpler to type just the first part of the address - **<ftp://ftp.viewcast.com/>**- and then click on the list of directories that display until you reach the **winXP/latest** location. Refer to your browser's help files for more specific and detailed assistance.
4. Download the web package file in **winXP/latest** to your hard disk.
5. The *Found New Hardware* wizard displays detecting each Osprey-540 card in the computer. Follow the directions in Canceling Out of the Found New Hardware Wizard at each prompt.

6. Run the web package program:
 - a. Click the **Start** button.
 - b. Click **Run**.
 - c. Enter *<pathname>* in the dialog box, where *<pathname>* is the location and name of the file that you have downloaded.
 - d. Click **OK**.
 - e. The program prompts for a temporary location for unpacking the install files.
 - f. See Option A: Run the Installation Program (Recommended) for a full description of the Installation Program steps.
-



These files are not automatically deleted after setup has run. This feature exists to offer the option of performing the manual Plug and Play install later. If you want to conserve disk space, make a note of where these files are being unpacked, and delete them after the install.

Two Install Scenarios

There are two installation scenarios that might apply:

- ◆ **Scenario 1: Osprey Card(s) not Physically Installed in the PC**
- ◆ **Scenario 2: Osprey Card(s) Physically Installed, but Osprey Software not Installed**

In all cases, the most efficient and complete installation method is to run the **setup.exe** program on the product CD or in the web package that you downloaded. The setup program automates the Plug and Play steps required to install the drivers and ensures that they are performed correctly. It also installs the bundled applets and User's Guide. If you have multiple Osprey capture cards in the system, it configures all of the boards at the same time.



You can skip the detailed instructions if you are upgrading from one Osprey driver version to another. Just run the **setup.exe** file to install all the updated components.

Scenario 1: Osprey Card(s) not Physically Installed in the PC

This Pre-install Scenario is the method that we recommend if you are installing an Osprey card for the first time on a system and the Osprey software has not yet been installed. After the install is run and as soon as an Osprey card is installed in the PC, the card is detected and its drivers are started automatically.

Using Windows Explorer, locate and access the CD-ROM drive containing the Osprey Installation CD-ROM.

1. Navigate to the **WINXP** directory.
2. Double-click **SETUP.EXE**.

The Osprey-540 Video and Audio Capture Driver window displays.

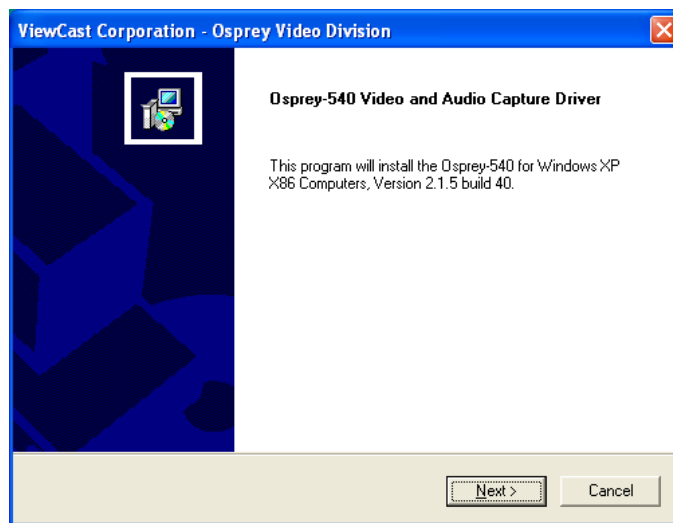

3. Click **Next**.

The Information window displays.

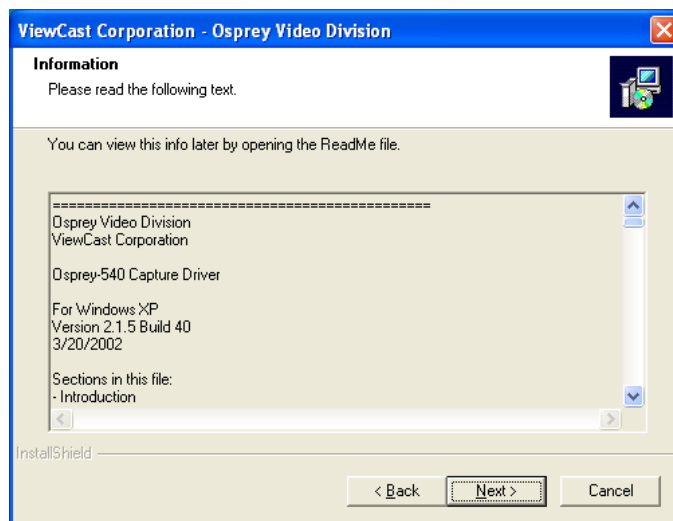

4. Click **Next**.

The Software License Agreement window displays.

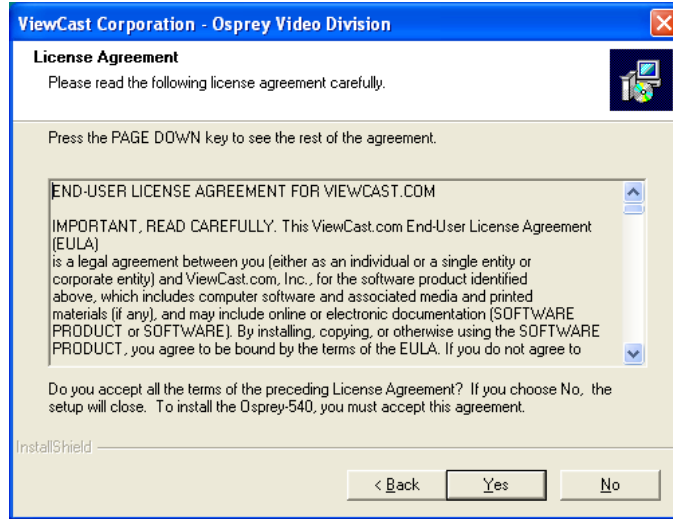

5. Click **Yes** to accept the End User Software License Agreement. If you do not wish to accept the agreement, click **No** to terminate the installation routine.

The Select Components window displays.

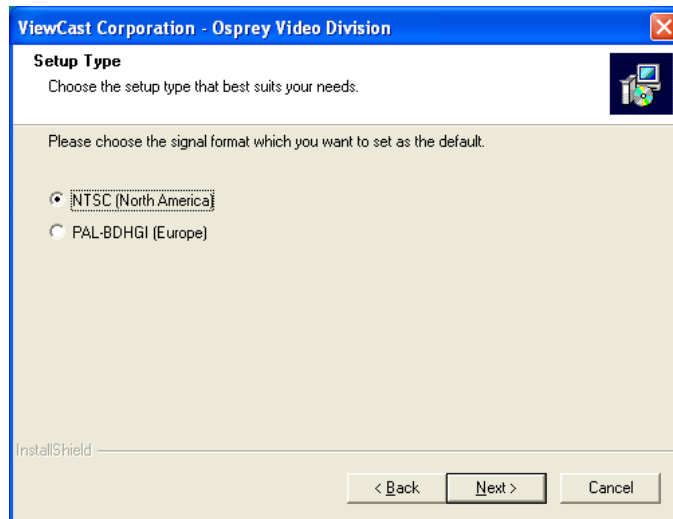

6. Click **Next**.
The Choose Destination Location window displays.

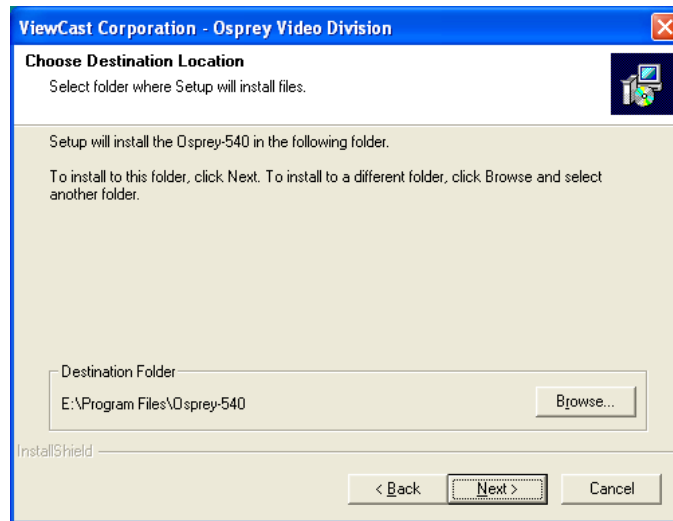

7. Click **Next**.
The Select Program Folder window displays.

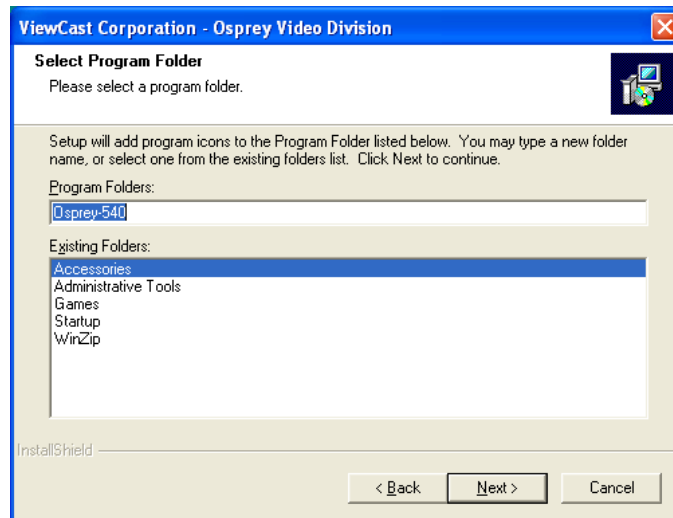

- Click **Next**.
The Start Copying Files window displays.

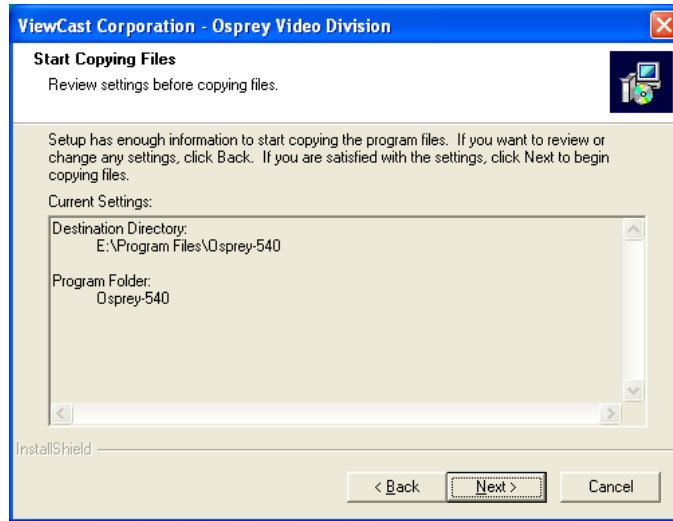

- Click **Next**.
A question window displays.

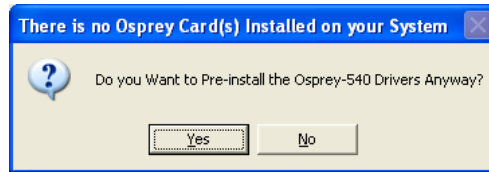

- Click **Yes** to continue the installation process.
A question window displays.

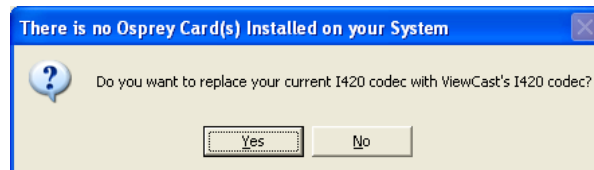

- Click **Yes**.
A question window displays.

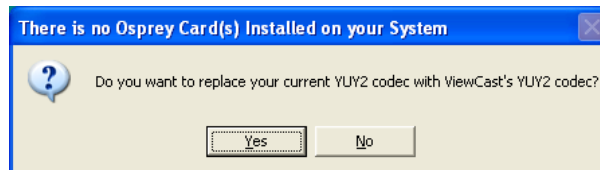

12. Click **Yes**.

A question window displays.

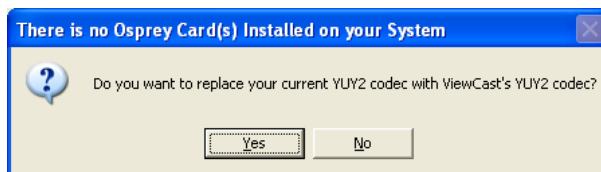

13. Click **Yes**.

A question window displays.



14. Click **Yes** to place the shortcut on your desktop. If you do not want the shortcut on your desktop, click **No**.

The Setup Complete window displays.

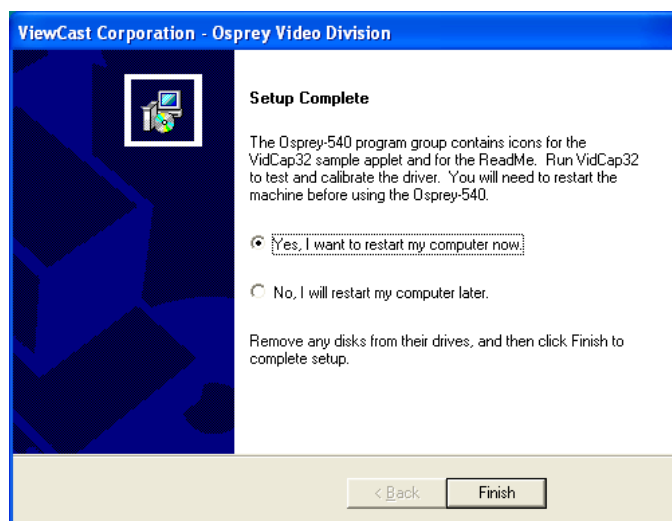

15. Click **Finish**.

The Setup Complete window displays.

If you are not installing the Osprey card at this time, click **No** then **Finish** to proceed. When you start your computer after installing the Osprey hardware, the **Found New Hardware Wizard** runs upon detecting new hardware. The sequence of windows are similar to that in [Appendix H - Adding/Moving Boards in Windows 2000](#).



The Osprey card does not need to be installed at this time. You also do not need to restart the computer at this time.

Scenario 2: Osprey Card(s) Physically Installed, but Osprey Software not Installed

In this case you have two options:

- ◆ **Option A: Run the Installation Program (Recommended)**
- ◆ **Option B: Use the New Hardware Found Wizard (Not Recommended)**

Option A: Run the Installation Program (Recommended)

When Windows XP is started for the first time after the Osprey card is installed, the *Found New Hardware* wizard displays one or more times. After Windows XP has finished starting, cancel out of the **Found New Hardware Wizard**.

To install the Osprey drivers:

1. Using Windows Explorer, locate and access the CD-ROM drive containing the Osprey Installation CD-ROM.
2. Navigate to the **WINXP** directory.
3. Double-click **SETUP.EXE**.

The Osprey-540 Video and Audio Capture Driver window displays.

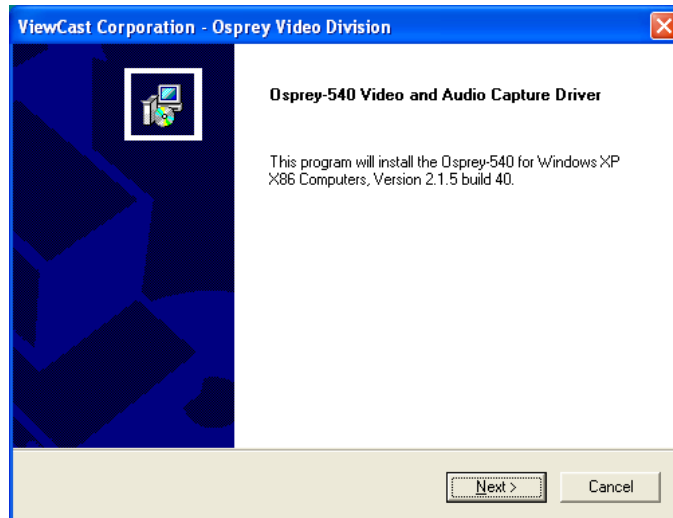

4. Click **Next**.
The Information window displays.

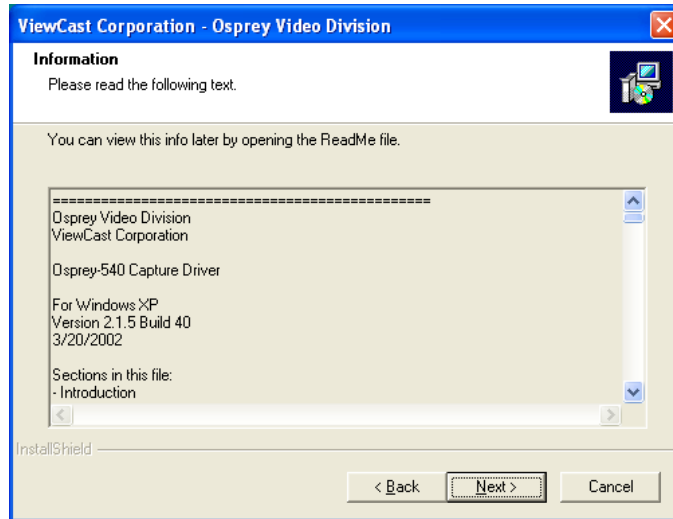

5. Click **Next**.
The Software License Agreement window displays.

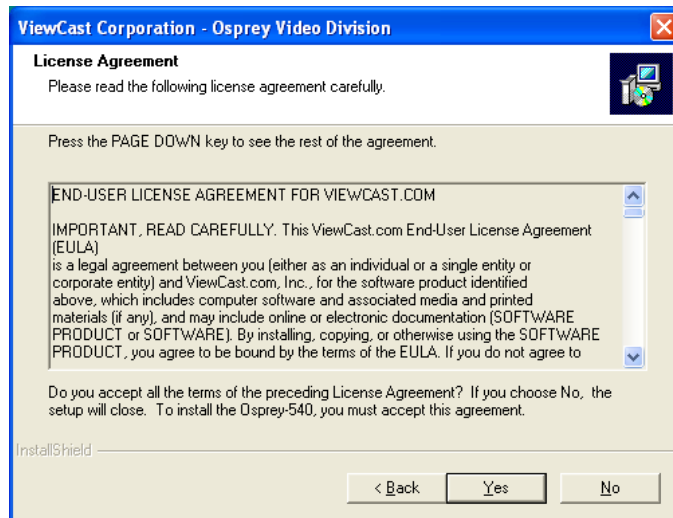

6. Click **Yes** to accept the End User Software License Agreement. If you do not wish to accept the agreement, click **No** to terminate the installation routine.
The Select Components window displays.

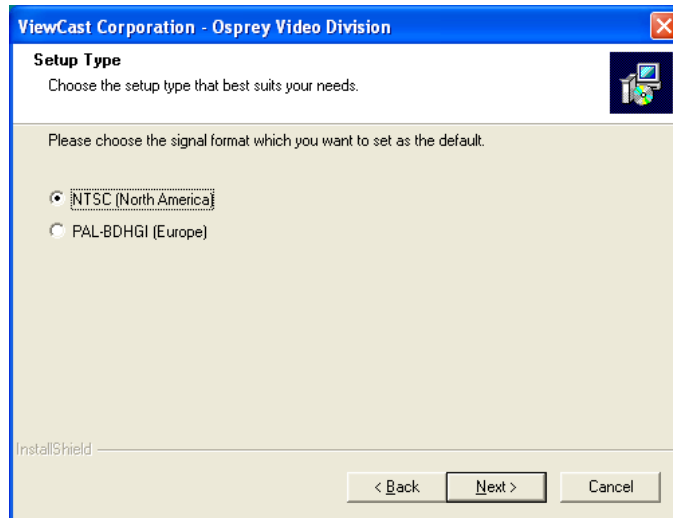

7. Click **Next**.
The Choose Destination Location window displays.

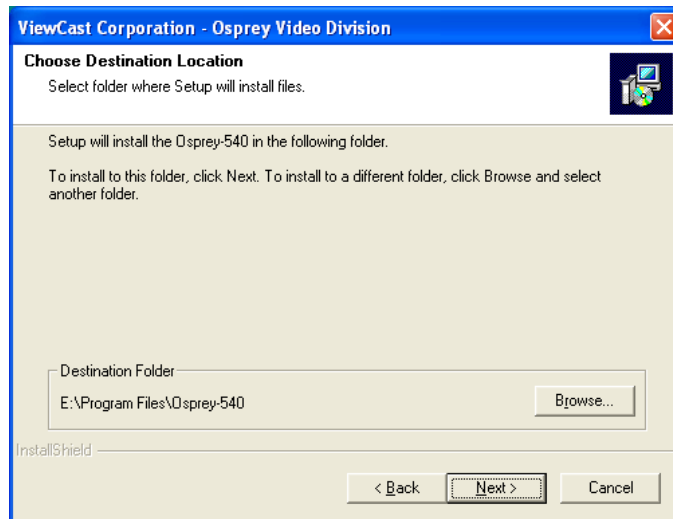

- Click **Next**.
The Select Program Folder window displays.

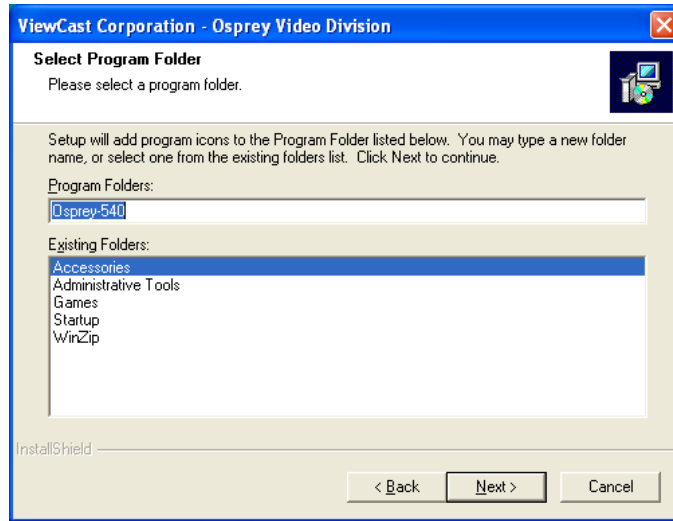

- Click **Next**.
The Start Copying Files window displays.

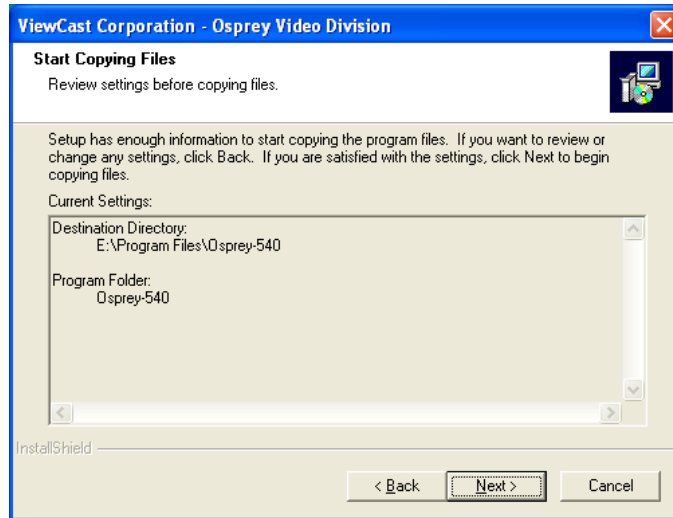

- Click **Next**.
A question window displays.

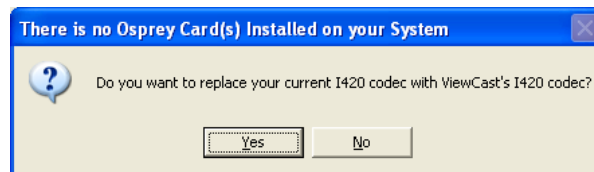

11. Click **Yes**.
A question window displays.

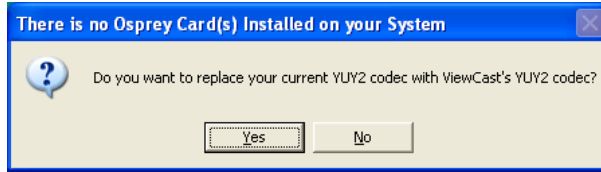

12. Click **Yes**.
A question window displays.

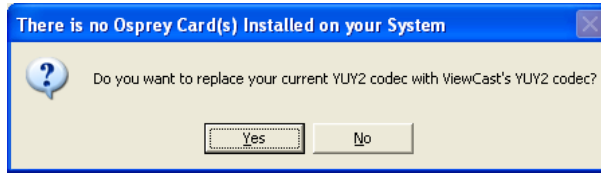

13. Click **Yes**.
A question window displays.



14. Click **Yes** to place the shortcut on your desktop. If you do not want the shortcut on your desktop, click **No**.
The *Setup Complete* window displays.

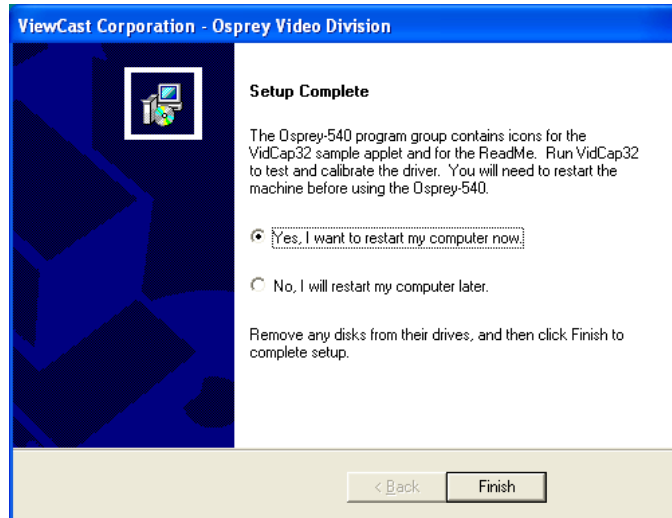

15. Click **Finish** to complete the installation and restart your computer. You must restart your computer before you can use the Osprey-540 card.

Option B: Use the Found New Hardware Wizard (Not Recommended)

This method is more complicated than Option A. It is particularly inconvenient if you are installing multiple cards at once, since each card has to be set up separately. This process installs only the driver and is useful only for updating the driver component. Furthermore, to get the sample applications and other required items, you must still run the setup.exe program detailed in Scenario 2, Option A.



The following windows and instructions assume that you are working with a computer on which the Osprey-540 software has never previously been installed.

When Windows XP starts, it detects the new card(s) and starts the Found New Hardware Wizard.



Please carefully note the terminology in the Found New Hardware Wizard.

For all Bt/Ct878-based Osprey cards, the Wizard detects two logical devices for each card - a *Multimedia Video Controller* device and a *Multimedia Controller* device.

The Multimedia Video Controller corresponds to the Osprey-540 video device. The Multimedia Controller corresponds to the Osprey-540 audio device.

The first window to display is the Found New Hardware Wizard.

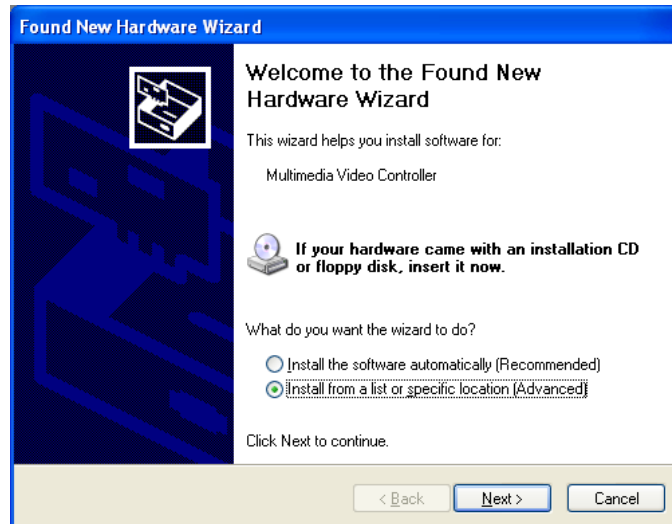

1. Click to select **Install from a list or specific location.**
2. Click **Next.**

The Found New Hardware Wizard window displays.

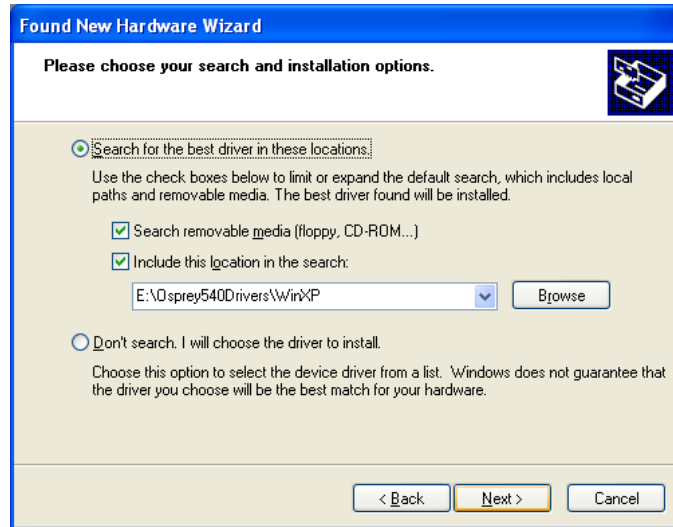

3. Click to select **Search for the best driver in these locations.** If the driver is not on a CD-ROM, type the destination in the field.
4. Click **Next.**

The Found New Hardware Wizard window displays.

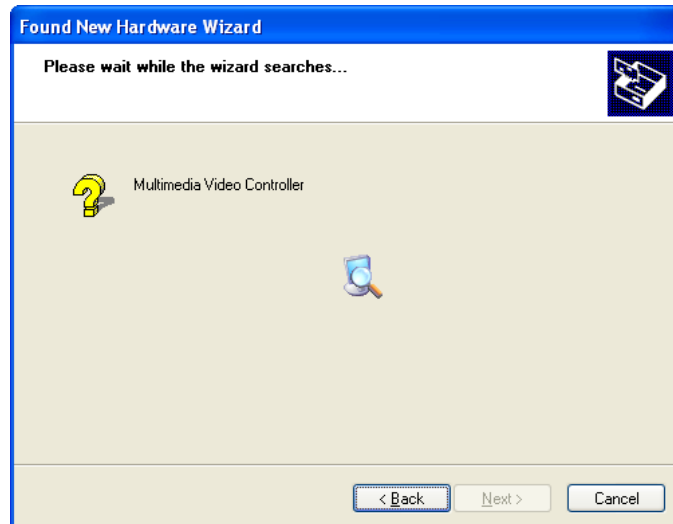

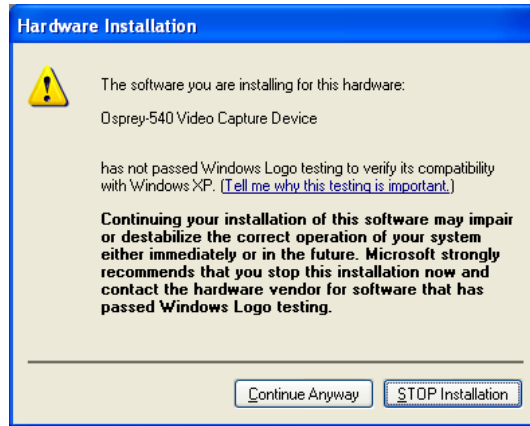

5. Click **Continue Anyway**.
The Found New Hardware Wizard window displays.

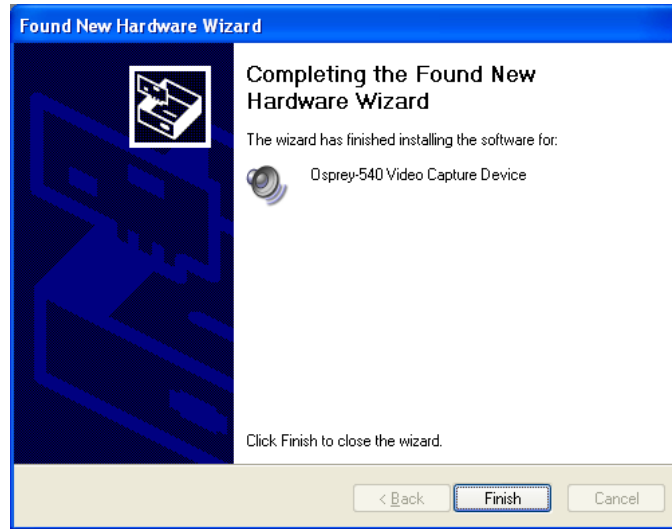

6. Click **Finish**.
The Found New Hardware Wizard window displays.

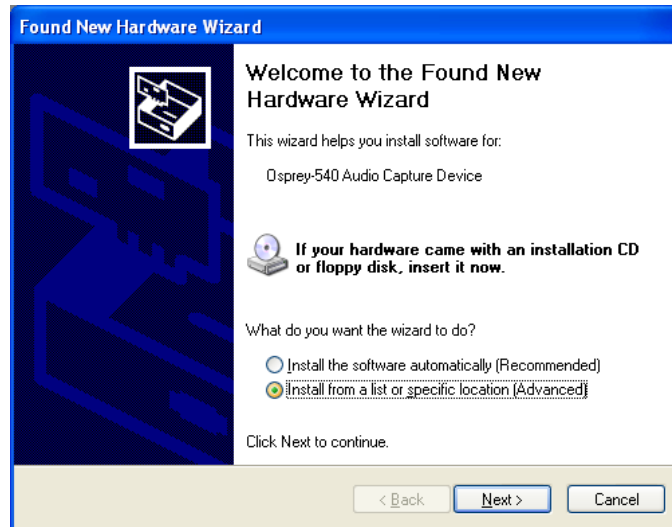

7. Click to select **Install from a list or specific location**.
8. Click **Next**.

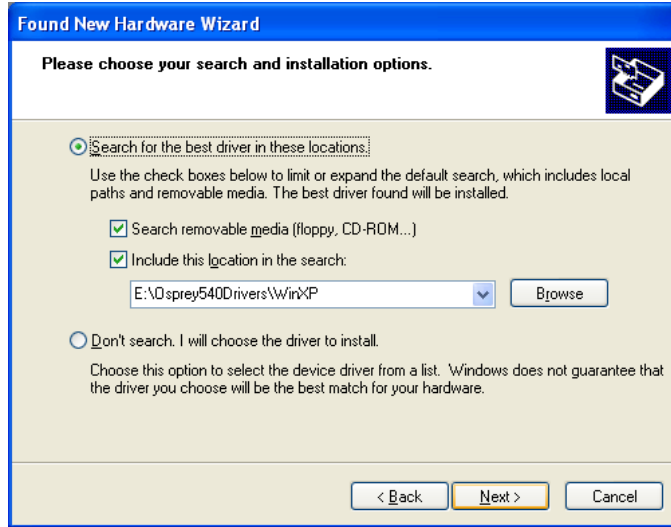

9. Click to select **Search for the best driver in these locations**. If the driver is not on a CD-ROM, type the destination in the field.
10. Click **Next**.
The Found New Hardware Wizard window displays.

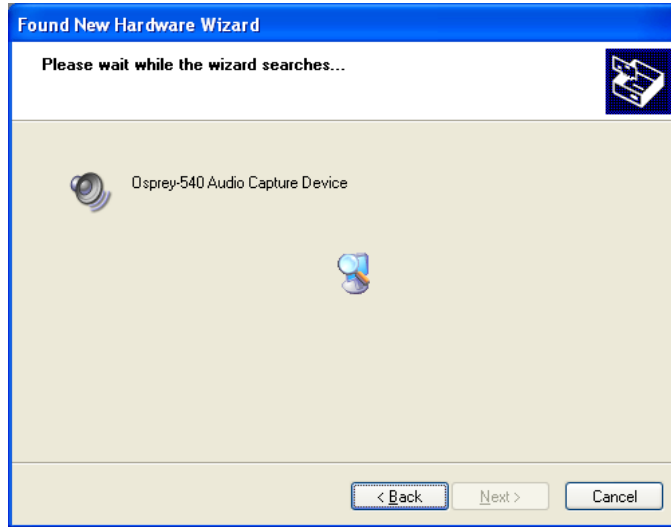



11. Click **Continue Anyway**.

The Found New Hardware Wizard window displays.



After completing the Found New Hardware Wizard, the software applications must also be installed. Navigate to the WinXP directory on the CD-ROM and double-click SETUP.EXE. For detailed instructions, see **Option A**.

Indeo

Ligos Technology's Indeo codec is provided on the Osprey-540 CD. Double-click on file **Indeo\Disk1\Setup.exe** to install this package containing compression and color formats.

Please see **Ligos Technology's Indeo** in Chapter 10 - VidCap32, AmCap, and Included Demo Programs for a description of this package.

Testing the Installation for Windows XP

1. Verify that the hardware installation is complete according to the directions in [Chapter 2 - Osprey-540 Hardware](#).
2. Connect a video signal source to one of the Osprey-540 connectors (Composite/S-video/SDI/DV).
3. Open the Osprey-540 group in the Start menu.
4. Click the **VidCap32** icon. Refer to [Chapter 8 - VidCap32](#) for more information on this application.
5. If your input is composite video, the screen displays a still video frame from the Osprey-540 board. Click the **Overlay** button. The screen should display moving video frames. If your input choice is not composite video, select the **Video Source** option under the **Options** menu. This brings up the Osprey-540's video capture driver configuration box where you can select your video input.
6. If the video area does not contain video, it could be for one of the following reasons:
 - a. The driver is looking for video on the wrong input connector. You can either move the video cable to another connector or reconfigure the driver using its Control Dialog. Refer to [Chapter 6 - Osprey-540 Video Control Dialog](#).
 - b. The video source is not turned on or activated.
7. If the video area is scrambled or has bad color, the signal format of your video source may be different from the signal format selected in the driver software. Since the driver defaults to NTSC-M signal format, users of PAL equipment always need to change the driver's signal format the first time they run the driver. Refer to [Chapter 6 - Osprey-540 Video Control Dialog](#) for more information.

Uninstalling the Software

If you need to remove the Osprey driver from your system:

1. Open the **Control Panel**.
2. Double-click **Add/Remove Programs**.
3. Click to select **Change or Remove Programs**.
4. Highlight the **Osprey-540 Driver** entry.
5. Click **Change/Remove** in the Osprey entry.
The uninstall program begins.
6. Click **Yes** to proceed.
7. Click **OK** when the process is complete.
8. Please reboot your computer to finish removing the driver.

Chapter 5 - Installing the Software - Windows NT 4.0

The Osprey Capture Card products contains a single CD for Windows 2000 and Windows NT 4.0.

After you've installed the software, you can test the card and software by running the included application program **VidCap32**.

Please note:

- ◆ Administrative privileges are required for installation.
- ◆ Before installing software, check the ViewCast.com support website or the ftp site for the any driver update releases subsequent to the software shipped on your CD. For the ViewCast.com support website, go to <http://www.ospreyvideo.com/> > **Downloads** > **Software & Drivers** > select WinNT and Osprey-540 from the table. To reach the ViewCast.com ftp site, go to <ftp://ftp.viewcast.com/pub/OSP-540/winnt/latest>. It's a good idea to check these sites periodically for update releases.
- ◆ The screens used to illustrate the installation steps may not be exactly what displays on your computer screen. In some cases, version numbers and other minor differences may display in the installation you are running.
- ◆ If you already have the Osprey driver software installed on your system and are updating it, you do not have to remove the old version before installing the new version. The installation program removes or replaces any files or registry settings that are outdated.
- ◆ If you have not installed Microsoft's DirectXMedia package, it is required to run Windows Media Encoder 7. It is included on your Osprey-540 CD-ROM.



The DirectXMedia package is distributed with Microsoft's DirectX 7.0a SDK which can be ordered on CD from:

<http://msdn.microsoft.com/directx/downloads.asp>

The DirectXMedia package has also been distributed on the Platform SDK CD-ROM within the MSDN subscriptions.

Installing from CD

Downloading and Installing Updated Drivers

Setup Program: Details

Testing the Installation for Windows NT

Uninstalling the Software

Installing from CD

If necessary, follow the directions in [Chapter 2 - Osprey-540 Hardware](#) to install the Osprey card. This software installation procedure works properly only if the card is already installed.

1. Turn on the machine and start Windows NT.
2. If you are updating from a previous version of the driver, it is necessary to uninstall the old driver before installing the new driver. Please refer to [Uninstalling the Software](#) for instructions.
3. Insert the Osprey-540 Driver CD into your CDROM drive. The installation instructions assume this is the (D:) drive. Substitute the proper drive as it is configured on your system, if necessary.
4. Run the installation program
 - a. Click the **Start** button
 - b. Click **Run**
 - c. Enter **D:\WinNT\Setup** in the dialog box
 - d. Click **OK**
5. The installation program steps are self-explanatory for many users. If you need additional information, please refer to the section entitled [Setup Program: Details](#).
6. The driver and demo program are ready for use as soon as the installation program completes and you have rebooted the system. We suggest you test the driver immediately. Refer to the section entitled [Testing the Installation for Windows NT](#).

Downloading and Installing Updated Drivers

1. Install the Osprey board in the PC if you have not already done so, turn on the machine and start Windows NT.
2. The latest software drivers for Osprey-540 Capture Cards are available via FTP (file transfer protocol) at the following location:
<ftp://ftp.viewcast.com/pub/OSP-540/winnt/latest>
There are also links to the drivers from our web site at <http://www.ospreyvideo.com/>.
3. Use your web browser, such as Microsoft Internet Explorer or Netscape Navigator, to find our FTP site and download the file. Type the FTP address shown above into the address box at the top of your browser window. You may find it simpler to type just the first part of the address - <ftp://ftp.viewcast.com> - and then click on the list of directories that display until you have reached the **winnt/latest** location. Refer to your browser's help files for more specific and detailed assistance.

4. Download the web package in **winnt/latest** to your hard drive.
 5. It is necessary to uninstall your existing Osprey-540 driver before installing a newer version of the driver. Follow the instructions in Uninstalling the Software and restart your computer before beginning the new install procedure.
 6. Run the web package program
 - a. Click the **Start** button
 - b. Click **Run**
 - c. Enter *<pathname>* in the dialog box, where *<pathname>* is the location and name of the file that you have downloaded
 - d. Click **OK**.
 7. The program prompts you for a temporary location in which to unpack the installation files and starts the setup program. The setup program guides you through the installation steps. For many users this process is self-explanatory. If you need additional information, please refer to the section entitled **Setup Program: Details**.
-



The installation files are not automatically deleted after setup has run. If you want to conserve disk space, make a note of the temporary location where these files are being unpacked and delete them after the installation.

8. You must restart the computer before the driver and sample applications are ready for use. We recommend that you test the driver immediately after restarting your computer.
-

Setup Program: Details

The setup program presents a sequence of windows and dialogs to guide you through the setup process. In general, click the **Next >** button to continue to the next screen. At any point you can click **< Back** to return to a previous screen or **Cancel** to exit the installation.

1. The installation of the Osprey-540 Driver for Windows NT begins with a confirmation that the setup program is beginning.
The Welcome window displays.
2. Click **Next**.
The Information window displays.
3. Click **Next**.
The Software License Agreement window displays.
4. Click **Next**.
The Signal Type window displays.
5. Click to select the signal format default for your Osprey-540.
6. Click **Next**.
The Choose Destination Location window displays.
7. Click **Next**.
The Select Program Folder window displays.



The destination location is the folder where VidCap32 (the demo applet), ReadMe, and other auxiliary files are located. (The core video capture driver files are located in Windows NT system directories regardless of the destination location chosen here.) The default location, in the Program Files folder, should be appropriate for most systems. Click the **Browse** button near the bottom of the dialog if you want to change the location.

8. Click **Next**.

The Start Copying Files window displays.



The setup program suggests placing the Osprey icons in a new program folder entitled "Osprey 540." You can change this name by editing the Program Folders field, or you can add the icons to an existing folder by highlighting it in the Existing Folders window.

9. Click **Yes** to place the Osprey Special Offers shortcut on your desktop. If you do not want the shortcut on your desktop, click **No**.

If another kind of video capture driver is already installed on your system, the question below displays.



10. Click **Yes** to make the Osprey driver your primary video capture driver, unless you have a particular reason for doing otherwise. Refer to [Appendix D - Using the Osprey Video Capture Driver with Other Drivers](#) for more detailed information about this message.

If another kind of audio capture device such as a soundcard is already installed on your system, a message similar to the one above displays asking, "Do you want to make this your primary audio capture driver?"



11. Click **No** to continue using your soundcard as your primary audio recording device.

The Setup Complete window displays.

12. Click **Finish**.
13. Restart Windows NT.



To change your setup at a later time, see [Chapter 7 - Capturing Audio](#).

Testing the Installation for Windows NT

1. Verify that the hardware installation is complete according to the directions in [Chapter 2 - Osprey-540 Hardware](#).
2. Connect a video signal source to one of the Osprey-540 connectors (Composite/S-video/SDI/DV).
3. Open the Osprey-540 group in the Start menu.
4. Click the **VidCap32** icon.
5. If your input is composite video, the screen displays a preview mode window with live video. Click the **Overlay** button. The screen should display moving video frames. If your input choice is not composite video, select the **Video Source** option under the **Options** menu. This brings up the Osprey-540 video capture driver configuration box where you select your video input.
6. If the video area does not contain video, it could be for one of the following reasons:
 - a. The driver is looking for video on the wrong input connector. You can either move the video cable to another connector or reconfigure the driver using its Control Dialog. See [Chapter 6 - Osprey-540 Video Control Dialog](#).
 - b. The video source is not turned on or activated.
7. If the video area is scrambled or has bad color, the signal format of your video source may be different from the signal format selected in the driver software. Since the driver defaults to NTSC-M signal format, users of PAL equipment always need to change the driver's signal format the first time they run the driver. See [Chapter 6 - Osprey-540 Video Control Dialog](#).

Uninstalling the Software

If you need to remove the Osprey driver from your system:

1. Open **Control Panel**.
2. Double-click **Add/Remove Programs**.
3. Click the **Install/Uninstall** tab.
4. Click to select the **Osprey-540 Driver** in the list of programs.
5. Click **Add/Remove**.
The uninstall program begins.
6. Click **Yes** to proceed.
7. Click **OK** when the process is complete.
8. Please reboot your computer to finish removing the driver.



You have the option of deactivating the Osprey drivers without permanently uninstalling them. For example, this option allows you to use another device as your primary video capture device. Refer to [Appendix D - Using the Osprey Video Capture Driver with Other Drivers](#) for more information.

Chapter 6 - Osprey-540 Video Control Dialog

Accessing the Dialog

General Features of the Dialog

The easiest way to become familiar with the video capabilities of the Osprey-540 cards is to run the included video capture application VidCap32 and look at its menus and dialogs. **Chapter 8 - VidCap32** focuses on the underlying video capture driver and the control dialogs that you can access from VidCap32.

The Osprey-540 video capture driver has a unified tabbed dialog for setting up all driver parameters. There are six pages within the dialog:

The Source Page

The Format Page

The Closed Caption Page

The Configuration Page

The Advanced Features Page

The Logo Page

The SimulStream Page (described in detail in the SimulStreaming User's Guide)

The menu selections **Options -> Video Source** and **Options -> Video Format** access the Control Dialog's Source and Format pages, respectively.

The selection **Options -> Video Display** accesses the Closed Caption page.

Accessing the Dialog

The normal way to access the dialog is through a menu entry or control button belonging to the application program. For example, VidCap32 offers the following three menu entries for accessing the dialog: **Options > Source**, **Options > Format**, and **Options > Display**. Once you are in the dialog, you can move to any other page by clicking on its tab. For example, to access the Configuration page from an application, open the Source, Format, or Display (Closed Caption) page and click the **Configuration tab**.

Another way to access the Configuration page under Windows NT is through the **Control Panel** using the following command sequence:

1. Open the system control panel and **Multimedia**.
2. Click the **Devices tab**.
3. Open **Video Capture Devices**.
4. Highlight **Osprey-540 Video Capture Driver**.
5. Click **Properties**.
6. Click **Settings**.

Another way to access the Configuration page under Windows 2000 is through the **Control Panel** using the following command sequence:

Steps:

1. Open the system control panel and **Sounds and Multimedia**.
2. Click the **Hardware tab**.
3. Highlight Legacy Video Capture Devices.
4. Click the **Properties button**.
5. Click the **Properties tab**.
6. Highlight **Osprey-540**.
7. Click the **Properties button**.
8. Click the **Settings button**.

To access the Configuration page under Windows XP:

1. Open **My Computer -> Control Panel -> Sound, Speech, and Audio Devices**.
2. Click **Sounds and Audio Devices**.
3. Click the **Hardware tab**.
4. Select **Legacy Video Capture Devices**.
5. Click **Properties**.
6. Click the **Properties tab**.
7. Select **Osprey-540 Video Capture Driver**.
8. Click **Properties**.
9. Click **Settings**.

General Features of the Dialog

These are the common elements found on all pages of the dialog.

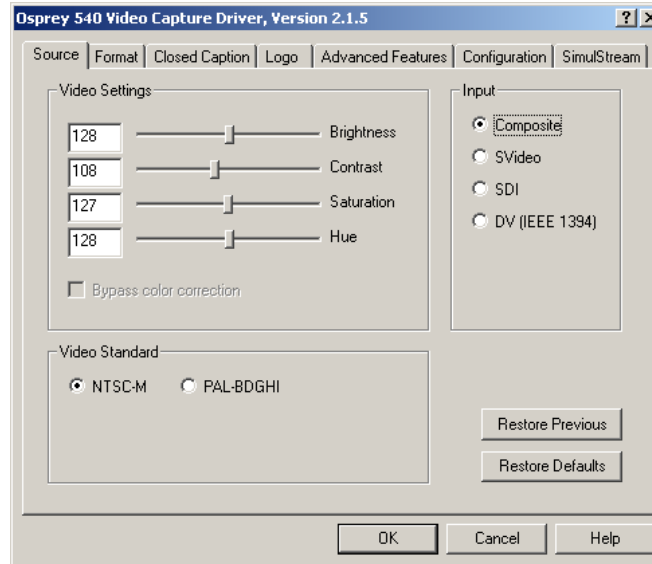

OK

Cancel

Restore Defaults

Restore Previous

Apply to All Boards

Help

OK

The **OK** button exits the dialog, saving the settings you have currently chosen. If you have made changes on two or more pages of the dialog, or for two or more boards, all of these changes are saved.

Cancel

This button exits the dialog box without saving any changes. If you have made changes on two or more pages of the dialog, or for two or more boards, all of these changes are discarded.

Restore Defaults

This button restores the settings on the current page, for the currently selected board only, to the way they were when the Osprey software was installed.

Restore Previous

This button restores the settings on the current page, for the currently selected board only, to the way they were at the start of the *previous* dialog session.

Help

Clicking **Help** accesses the pages of this manual covering the currently selected tab.

The Source Page

Use the Source page to set the characteristics of the input video.

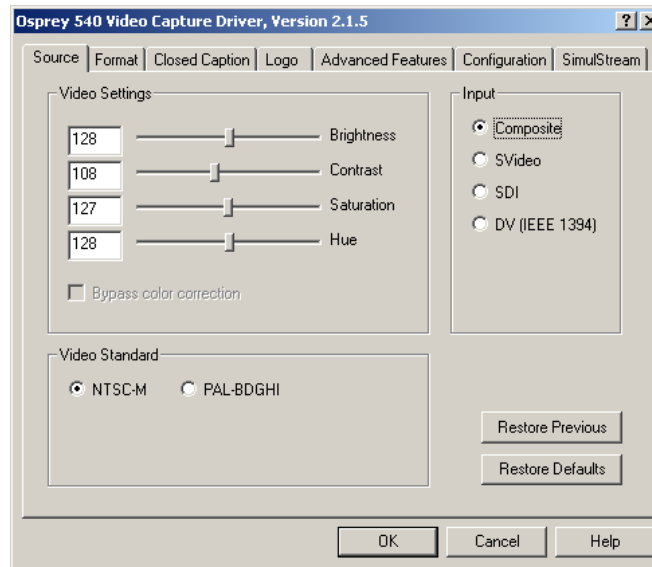

Input

Video Standard

Video Settings

Bypass Color Correction

Input

The Input field has buttons for the card's Composite, S-Video, SDI and DV input connectors.

If Preview or Overlay mode is enabled in your application, you can usually see the results of your selection immediately without exiting the dialog. However, if you switch between inputs that have two different signal formats, such as NTSC or PAL, the video does not display correctly until you exit the dialog.

Video Standard

Video Standard or Signal refers to whether the video signal format is NTSC, PAL, or SECAM. The Osprey-540 supports only NTSC-M and PAL-B,D,G,H,I formats. Depending on the exact product version you have, buttons for some or all of the following formats are displayed:

- ◆ NTSC-M – North America
- ◆ PAL-B, D, G, H, I – many countries in Europe and elsewhere. B, D, G, H, and I refer to five nearly identical subformats.

The following three standards are not supported by the Osprey-540 at this time. However, there are other Osprey video capture boards that do support these standards. Please visit the web site at <http://www.ospreyvideo.com/> for more information.

- ◆ NTSC-J – Japan
- ◆ PAL-M – Brazil
- ◆ PAL-N, NC – Argentina, Paraguay, Uruguay

Full-sized NTSC-M, NTSC-J, and PAL-M have 525 lines total, 480 lines visible, per frame and a display rate of 60 fields per second, or 30 interlaced frames per second.

Full-sized PAL (other than PAL-M) and SECAM have 625 lines total, 576 lines visible, per frame and a display rate of 50 fields per second, or 25 interlaced frames per second.

The standard frame sizes are different for NTSC and PAL. For example, the half-frame size in pixels is 320x240 for NTSC, and 384x288 for PAL. If you have selected a standard frame size (Full, 1/2, 3/8, or 1/4), the driver automatically adjusts the frame size to correspond to the standard. If you have created a custom size, it does not change when you switch between NTSC and PAL/SECAM.

Changes to the standard controls do not take effect until you exit the dialog.

Video Settings

These four slide controls set Brightness, Contrast, Hue, and Saturation. These settings are stored separately for each video source.

NOTE: When using these controls, be sure that the preview mode or overlay mode is enabled, so that you can immediately see the effects of your changes.

When a video source with PAL signal format is used, the Hue setting is not adjustable and the Hue control is grayed out.

When using a digital source (SDI or DV), the Brightness, Contrast, and Saturation settings affect encoded video. The Hue setting is not adjustable on SDI and DV video sources.

The Restore Previous or Restore Defaults button can be used to restore the previous video settings.

Bypass Color Correction

Check Bypass color correction to turn off all saturation, contrast, and brightness conversion in hardware and pass digital video data directly to the host. This is most useful for the SDI and DV input sources. This checkbox applies ONLY to digital video sources.

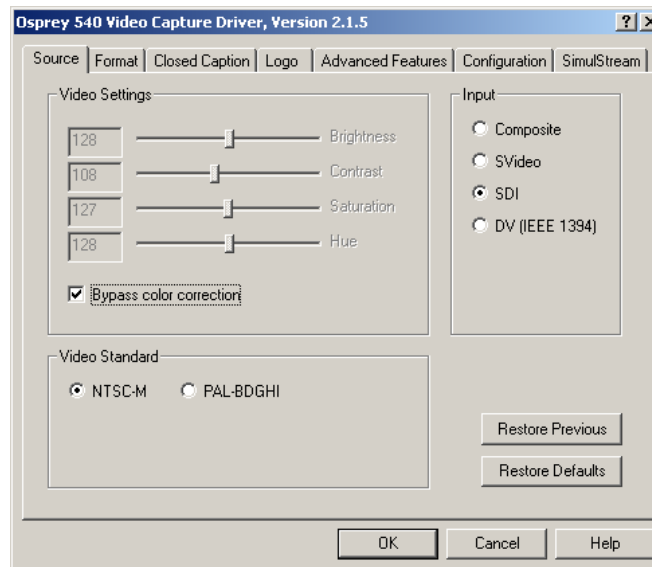

The Format Page

Use the Format page to set the color format and size of the image.

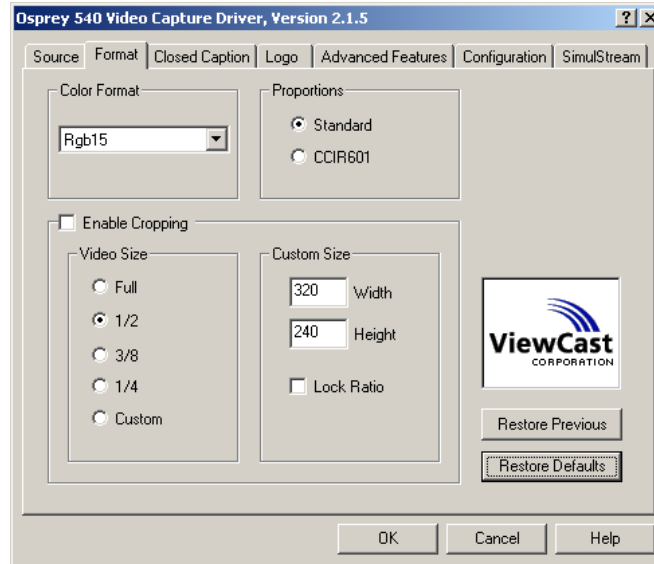

Color Format

Video Size

Custom Size

Proportions (Pixel Aspect Ratio)

Cropping (please see the **CropApp Manual** for detailed instructions on using this feature)

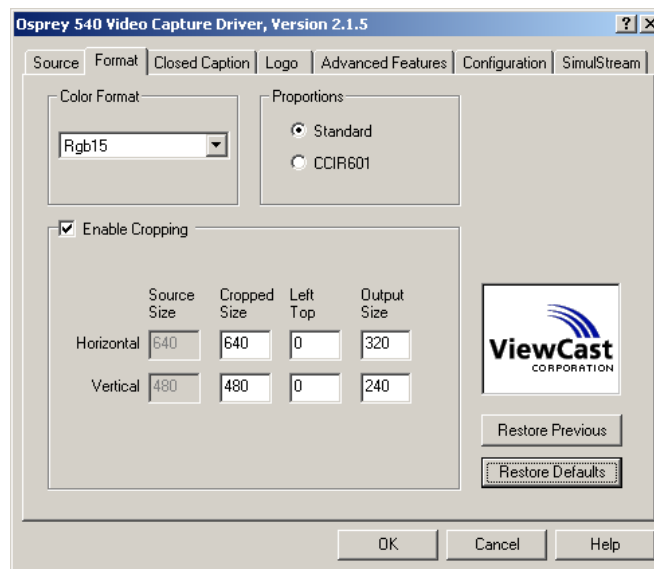

Color Format

The Color Format is the arrangement of data bits representing the colors of each pixel. For example, in the RGB15 format, each pixel of data is stored as 5 bits of red, 5 bits of green, and 5 bits of blue color information.

Video delivered by the Osprey board to the system is in uncompressed format. It is possible to compress the video at a subsequent stage of processing. However, this dialog field refers specifically to the uncompressed raw video that the board delivers to the system.

The color format you choose applies to Captured video and to Preview video. It does not apply to Overlay video. Overlay video is always matched to the display adapter's current screen format - except when greyscale mode is selected. Overlay video is therefore as fast and efficient as possible, but the color rendering may differ very slightly from what you capture. Preview mode renders colors exactly, but it is slower and consumes more system resources.

Changes to Color Format take effect only after you exit the dialog.

For a more detailed description of the color modes available, refer to [Appendix B - Color Modes](#).

Video Size

The Video Size field allows you to select between the various sizes given below. Changes made to Video Size take effect only after you exit the dialog.

Size	Width x Height	Also known as:
Full	640 x 480	
1/2	320 x 240	CIF
3/8	240 x 180	
1/4	160 x 120	QCIF

The width and height shown are in pixels for the North American NTSC-M video format in the square (standard) aspect ratio. For further details, refer to [Appendix C: Video Sizes](#).

There is a fifth button, **Custom**, that becomes selected whenever a non-standard size is entered in the **Custom Size** field. See Proportion (Pixel Aspect Ratio) for more detailed information.

Custom Size

The Custom Size field allows you to set customized width and height values different from the standard preset values of full, 1/2, 3/8, and 1/4.

If the **Fixed Ratio** box is checked, when you enter a new size in either the height or width box, both dimensions are adjusted proportionately. If this box is unchecked, the height and width may be entered independently. If the dimensions are different from normal screen proportions, the image is stretched horizontally or vertically.

The Osprey video hardware is not capable of drawing all possible widths. Depending on the color mode selected, it may require a width that is an even number of pixels or, for YVU9 and YVU12, a width that is a multiple of 16. The dialog lets you enter numbers that the hardware cannot utilize, but adjusts them as soon as you click on another field or button of the dialog.

See Proportion (Pixel/Aspect Ratio) for more detailed information.

Proportion (Pixel Aspect Ratio)

This dialog allows you to select between "Standard" (also called a Square aspect ratio) and "CCIR601" aspect ratio.

The maximum resolution of the CCIR601 mode is 720 pixels for both NTSC and PAL. The Standard/Square aspect ratio mode has a maximum resolution of 640 pixels for NTSC and 768 pixels for PAL. However, the inputs to the Osprey-540 all operate in the CCIR601 mode. The CCIR601 format is true of the analog inputs as well unless the Osprey-100 Analog Mode is selected. Thus, it is recommended that only the CCIR601 mode be used on the Osprey-540.

Note that since the sources are processed in a CCIR601 format, the full 768 pixels of the standard/square aspect ratio mode of PAL is not available. Only 720 maximum pixels are available. If the standard/square aspect ratio mode is selected for PAL, the Osprey-540 drivers limit the maximum resolution to only 720 pixels.

Also, many digital sources provide only 704 true pixels and not 720 pixels per line. Because of this, the Osprey-540 scales down from 704 pixels (i.e., a crop of 720 to 704) to the desired size. If 720 pixels are desired, for example, the result is an unscaled 720 pixels in width. If 704 pixels are desired, the result is an unscaled 704 pixels in width. If 352 pixels are desired, the result is a scaling from 704 down to 352 pixels in width (and not 720 down to 352).

Cropping

Please see [Cropping and Scaling](#) in this guide and also in the CropApp Manual for detailed instructions.

The Closed Caption Page

Use the Closed Caption page to enable or disable Closed Captioning and to control its characteristics.

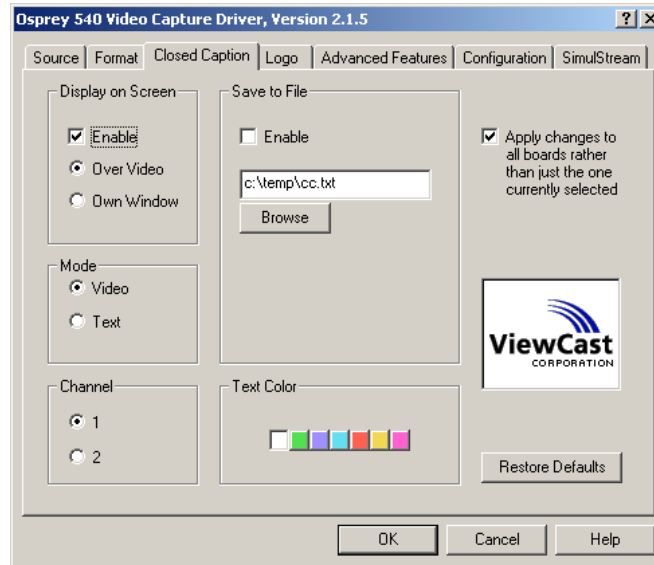

Display on Screen

Save to File

Mode

Channel

Text Color

Apply to All Boards

Closed Captioning is a method of encoding and displaying text such as movie dialog captions or stock quotes as part of NTSC video. The text is similar to movie subtitles in appearance. Closed Captioning is widely available on broadcast video, cable, videotapes, and videodisks.

The Osprey-540 video driver provides a complete implementation of the Closed Captioning standard and special extensions that are made possible by the capabilities of a PC. At the moment, the Osprey-540 only provides support for Closed Captioning on the analog video inputs. For more information, see No Closed Captions on Digital Video in Section 8 - Troubleshooting.

You can use Closed Captioning whenever the following conditions are met:

- ◆ You must be viewing a videotape, videodisc, or broadcast material that has Closed Captioning content. Look for a small "CC" logo on the packaging or in the program listing.
- ◆ Closed Captioning is for North American NTSC video only, not for PAL video.
- ◆ Closed Captioning must be enabled in the Osprey driver, using the Closed Caption dialog page as explained above.
- ◆ **Video Mode** and **Channel 1** must normally be selected as explained above. You might use **Text Mode** or **Channel 2** in specialized instances.
- ◆ In addition to the normal options of viewing or capturing Closed Captioning, you have the special capabilities to save the text to file as you view or capture it.

Display on Screen

The **Enable** checkbox enables display of Closed Captioning on the screen if it is checked and disables it if it is unchecked. Closed Captioning currently only is enabled for analog (Composite/S-Video inputs).

If you check or uncheck the **Enable** checkbox while Overlay or Capture mode is in effect, the change does not take effect until Overlay or Capture is stopped and restarted.

It is recommended that you disable Closed Captioning when using non-Closed Captioned video. If you leave Closed Captioning enabled, the software attempts to interpret regular video as Closed Captioning character codes, and may sometimes display spurious characters. It also slightly increases the driver's CPU usage.

The normal display mode is **Over Video**. In this mode the Closed Captioning is superimposed on the video field.

The **Own Window** option is a special proprietary mode for Closed Caption display. A separate window displays, and the text scrolls up in this window instead of appearing on the video field. This window disappears while you are capturing video and reappears after capturing video. This mode may be useful for some kinds of material, as the lines of text are not erased as quickly. The **Own Window** option, however, does not fully conform to Closed Caption standards, especially with regard to line placement. It may therefore give undesirable results with some kinds of highly formatted captions.

Save to File

A nice feature of Closed Captioning on a PC is that you can save the captions to a file for later review. The Save to File field contains three controls:

1. If checked, the **Enable** checkbox enables saving to a file.
2. The **Edit Box** allows you to designate a file in which the captions are saved.
3. The **Browse** button accesses a standard system dialog for locating a directory and file in which the captions are saved. When you choose a file that already exists (either by entering the file name or using the **Browse** button), new captions are appended to whatever was previously in the file.

You may enable saving to a file without enabling display of Closed Captioning on the screen; the two checkboxes are independent.



When SimulStream is in use, only one closed caption session is available to save to a file.

Mode

Video is the normal Closed Captioning display mode used with almost all videos and broadcast TV. **Text** is a specialized mode in which the entire 32 character by 15 row Closed Captioning area of the screen is blanked and used to display text. Use **Video** mode unless you know specifically that the material is **Text** mode.

Channel

Channel 1 is the channel normally used in almost all Closed Captioning. Some specialized material may use **Channel 2**.



Note that with most material, if you select **Channel 2**, you won't see any Closed Captions.

Text Color

The default appearance of captions is white text on black background. You can select the foreground text color to be one of six other colors here.

Apply to All Boards

If multiple boards are installed, changes can be applied to all of the installed boards simultaneously. If you only want to apply the changes to the selected board, do not select the Apply to All Boards check box.

The Logo Page

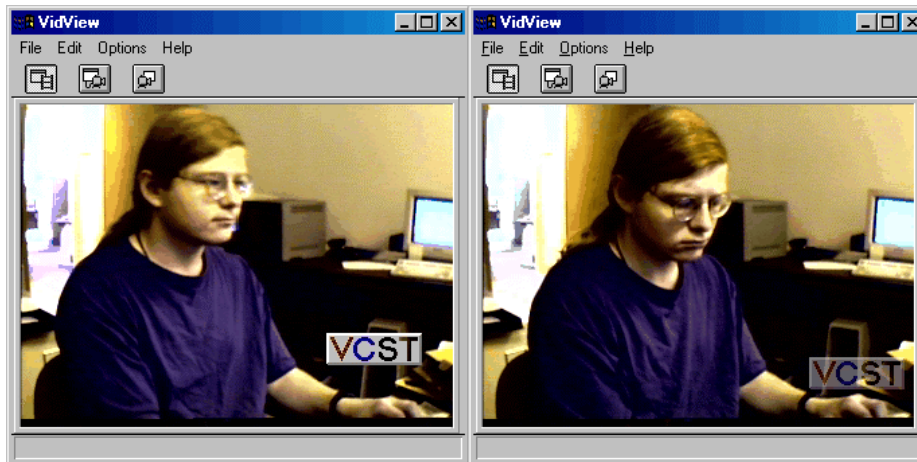

The Osprey Video Capture Driver allows you to superimpose a logo on captured video, as in the images above. The “VCST” logos shown illustrate some of the features for color keying and translucency that are described below.

Use the setup dialog’s Logo page to set up a logo. The logo page is actually a sequence of five pages that guide you through the steps of creating a logo and placing it on the video.

You cannot access the Logo page directly from most applications. Instead, open the Source or Format page of the dialog, then click on the **Logo tab**.

Capabilities

Step 0 - Before You Start

Step 1 - Creating and Enabling the Logo

Step 2 - Selecting the Logo File

Step 3 - Setting Key Color and Style

Step 4 - Positioning the Logo

Step 5 - Reviewing and Saving the Changes

Notes on Logos

Capabilities

A logo can be any artwork that is formatted as a 24-bit BMP file. Typically, a logo is a small graphic that is placed at the lower left of the image. In a technical application, however, a logo could be a crosshair pattern placed at the center of the image. The logo can theoretically be any size. However, the CPU must actively draw the image on every frame of video, and drawing a very large image, even if it is mostly transparent, degrades overall performance in high-throughput applications.

The driver can draw a logo on captured or streaming video, on preview video, or on DibDraw overlays. However, the driver cannot draw a logo on DirectDraw overlays. If you attempt to draw a logo on DirectDraw overlays, everything appears to work fine, except that the logo is not visible.

A logo's rectangle can be partially transparent so that the underlying video is visible. The transparent areas are defined by a Key Color – a particular (red, green, blue) value that is specially interpreted by the driver. For example, the sample logos use cyan with red, green and blue values of (0, 128, 128) as the key color.

A logo displays in either of two styles – normal and embossed. In normal style, the logo's non-transparent pixels simply replace whatever video underlies it. In embossed or translucent style, the logo's non-transparent pixels are averaged with the underlying video pixels, resulting in a more subtle effect.

For detailed instructions on setting up a logo, review the following steps:

Step 0 - Before You Start

Step 1 - Creating and Enabling the Logo

Step 2 - Selecting the Logo File

Step 3 - Setting Key Color and Style

Step 4 - Positioning the Logo

Step 5 - Reviewing and Saving the Changes

Step 0 - Before You Start

Create your artwork with the Windows Paint application or any other paint program that you like to use. Save it in 24-bit BMP format.

Before creating your own logo, however, you may want to experiment with the samples supplied with the driver. They are located in the Osprey program directory, by default `\Program Files\Osprey 540\Nt` on the default drive.

Have Preview or DibDraw Overlay mode running when you enter the dialog to see immediately the results of interactively defining and placing the logo. DirectDraw Overlay mode does not work for this purpose. To change from DirectDraw to DibDraw, – or to find out which one you are currently using – go to the dialog's **Configuration tab**, then stop and restart **Overlay mode**.

Step 1 - Creating and Enabling the Logo

Additional links:

[The Logo Page](#)

[Capabilities](#)

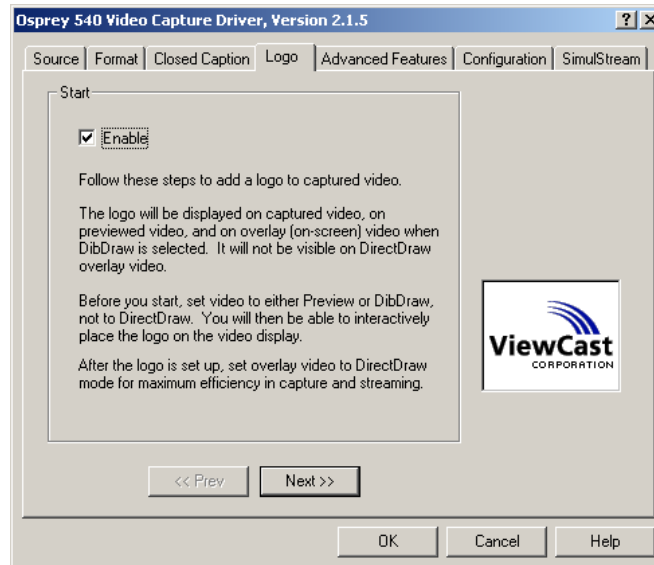

As you can see, the logo setup pages include detailed explanations at each step.

The first page handles only one consideration – whether logo drawing is enabled or not.

By default, the **Enable** box is not checked and therefore no logo displays. In this case, when you click **Next>>** you go directly to the last page (page 5) of the logo setup sequence.

If the **Enable** box is checked, you can click **Next>>** to step through all of the pages of the setup sequence.

Step 2 - Selecting the Logo File

Additional links:

[The Logo Page Capabilities](#)

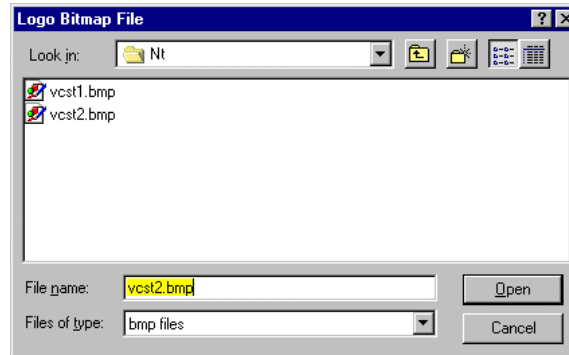
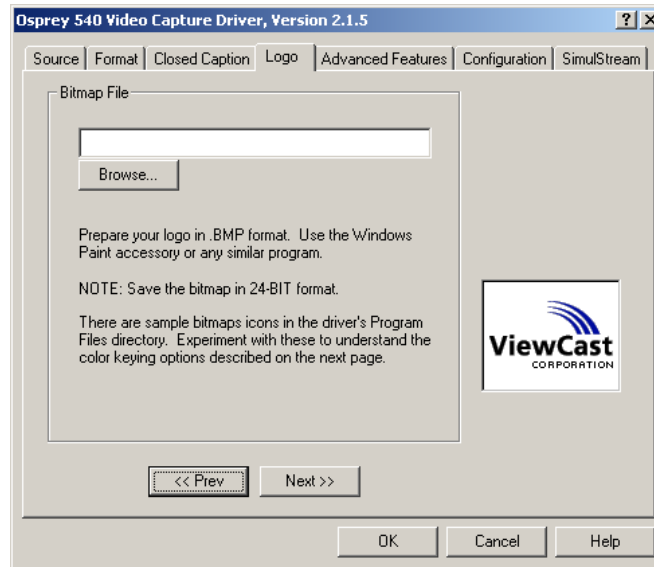

This screen should be nearly self-explanatory. You are selecting a BMP file, either your own artwork or one of the samples. You can type in the full pathname to the file or browse for it. When you have selected the file, click **Next>>**.

The sample logos are located in the Osprey program directory, by default \Program Files\Osprey-540\Nt on the default drive.

Step 3 - Setting Key Color and Style

Additional links:

[The Logo Page](#)

[Capabilities](#)

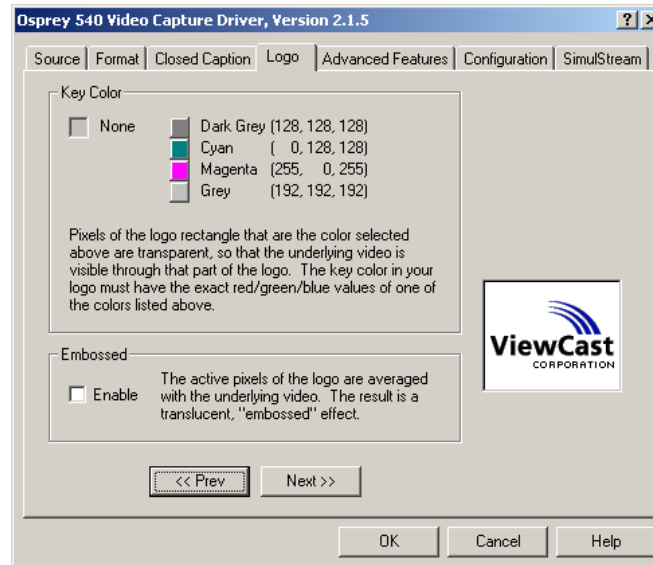

As previously noted, a key color is a (red, green, blue) color value that the driver treats specially. Logo pixels in that color do not display; the underlying video displays instead. This dialog sheet lets you choose one of four fixed key colors, or no key color. If you select **None** for the key color, all pixels from the logo display including all pixels in any of the key colors.

A key color must be a precise (red, green, blue) value. For example, if cyan is selected as a key color the pixel values must be exactly (0, 128, 128). A pixel of value (0, 127, 127) does not display transparent – it displays as cyan.

All four key colors are standard stock colors in Windows Paint.

If the **Embossed** box is checked, each pixel color value displayed is the average of the pixel value of the logo and the pixel value of the underlying video. If **Embossed** is not checked, the pixel color value is simply the value from the logo.

The key color setting takes precedence over the **Embossed** setting; that is, logo pixels in the key color are transparent, not averaged, even in **Embossed** style.

Step 4 - Positioning the Logo

Additional links:

[The Logo Page](#)

[Capabilities](#)

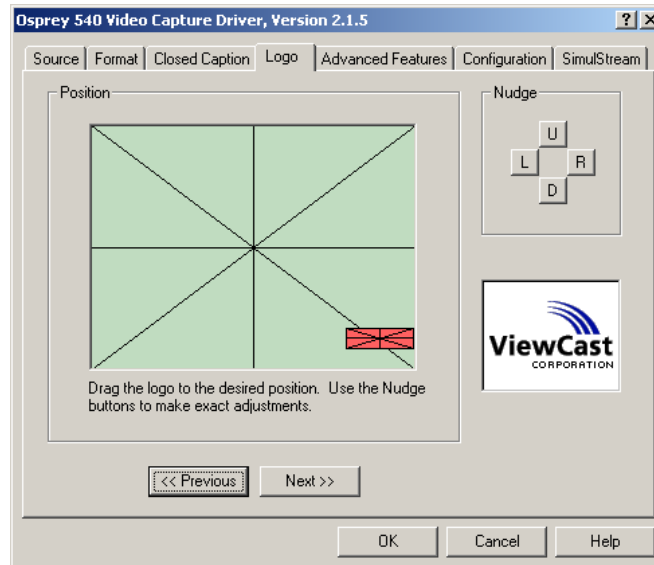

The **Position** control allows you to position the logo by dragging it with the mouse. The **Nudge** controls move the logo up, down, left or right one pixel at a time. They permit more precise adjustments than the **Position** control can achieve.

If Preview or DibDraw Overlay video is running, the logo moves on the video as you move it in the dialog.

If you position the logo in a certain way and then change the video size, the driver stretches the logo to maintain the same relative size, and places it in the same relative position. The stretched artwork may have jagged diagonal edges and not look as good as unstretched artwork prepared with the intended video size in mind.

Step 5 - Reviewing and Saving the Changes

Additional links:

[The Logo Page](#)

[Capabilities](#)

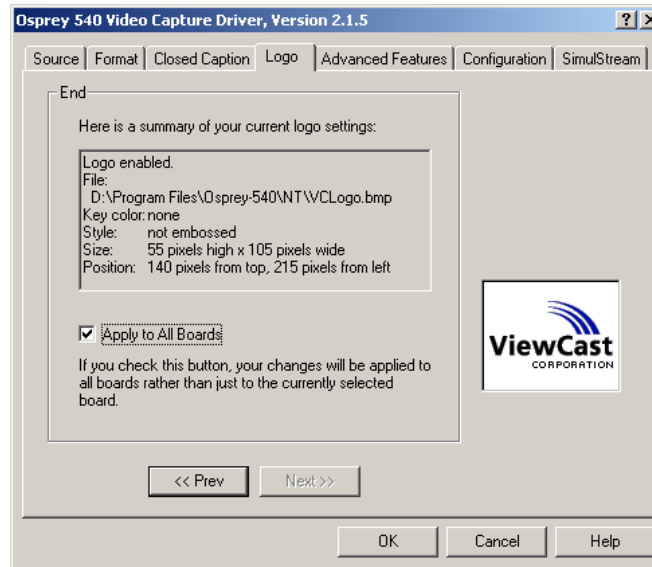

This page shows a text summary of the current logo configuration.

If you have multiple boards in the system, a checkbox entitled **Apply to all Boards** is shown. If you check this box, the logo changes you make to the current board are made to all the boards in the system.



If you have multiple boards in the system and the only change you make is to enable or disable logos, clicking **OK** with **Apply to All Boards** checked changes the enable/disable status of all boards but doesn't change any of the other settings. If, however, you make *any* logo changes other than enable or disable, **Apply to All Boards** copies the entire current configuration to all boards.

Notes on Logos

If you set up a logo with video set to one size, then resize video, the logo is scaled correspondingly. For example, if the logo is originally set up for 320 x 240 video, and you change to 640 x 480 video, the logo displays at twice the size of the original bitmap.

1. If you edit the logo settings while the logo is scaled up or down, an additional option entitled **Rescale** displays after **Enable**.

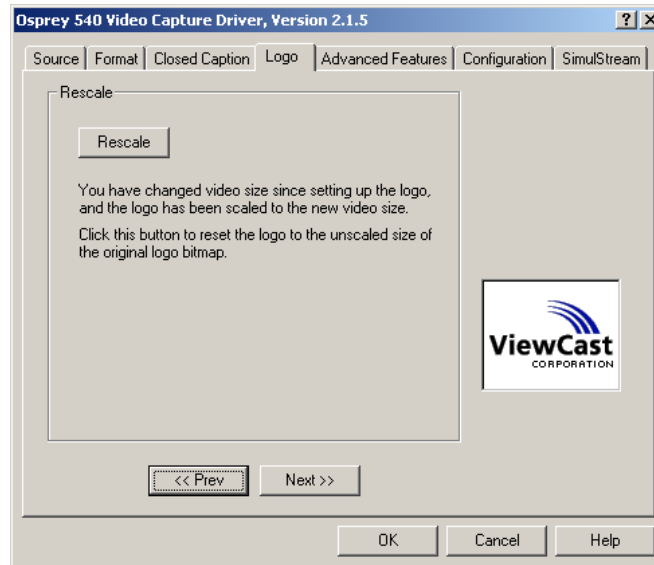

If you click the **Rescale** button on this page, the logo is resized to the same size as the original source bitmap.

If you do not click the **Rescale** button, you can edit the logo settings using the scaled logo. Even if you change to another bitmap image, the old scaling is maintained.

2. The driver can display color logos on YUV video – 4:2:2 packed, YUV12 planar, and YVU9 planar. The appearance may not be quite the same as the RGB version, however.
3. Detail of colored features may not be as crisp, because in the YUV modes color is not sampled at full pixel resolution.



DibDraw Overlay video is always RGB even when you have selected a YUV color format in the dialog. Preview video is always in the exact YUV or RGB format you have selected. Therefore, when using a YUV mode be sure to check the appearance of the logo in Preview mode before putting it to use.

4. When Grey8 video format is selected, all logos including color logos are displayed in greyscale.

Apply to All Boards

This option displays on relevant dialog windows when more than 1 Osprey card is installed in a system. The only dialog window tabs that can apply an operation to multiple boards are Closed Caption and Logo. The settings for all the boards are saved when you click **OK**; or all are discarded if you click **Cancel**.

The Advanced Features Page

Select a link below the screen for more information.

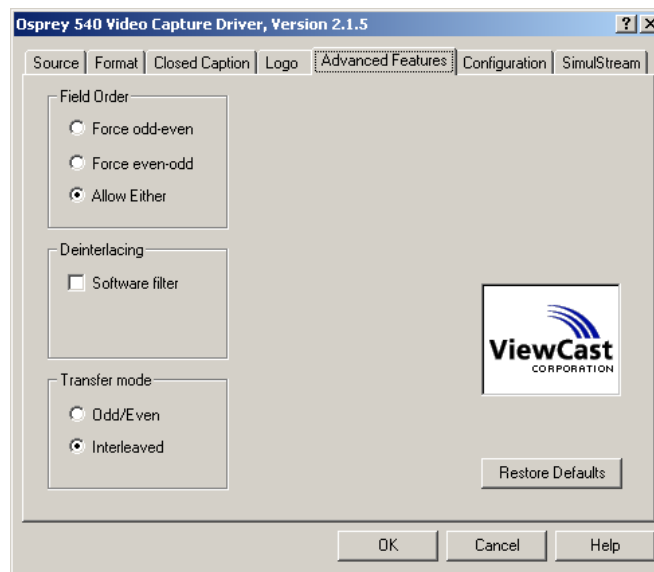

[The Transfer Mode](#)

[The De-Interlacing Motion Filter](#)

[Field Order](#)

Field Order

The Osprey-540 allows you to configure which pairing of fields will be used to construct a frame. For interlaced capture devices (most current video cameras) the field order does not matter and the 'Allow Either' setting will provide better performance in VFW preview mode. The default setting for this feature is 'Allow Either'. Use the force odd-even or force even-odd settings with a progressive scan camera. Consult your camera's technical documentation for the correct setting to use. Using the correct setting with a progressive scan camera will eliminate comb-like interlacing artifacts.

The De-Interlacing Motion Filter

The Osprey-540 offers software de-interlacing. This feature is optimized for Windows 2000 and later; it will consume fractionally more CPU cycles when enabled under Windows NT. Most video is provided for viewing in an interlaced format. For simplicity, NTSC is used in the following explanation of an interlaced format. NTSC video is basically composed of images taken 60 times a second. Each image is called a field, and there are odd and even fields. While these odd and even fields are temporarily adjacent to each other in time, the horizontal lines that make up these fields are spatially different.

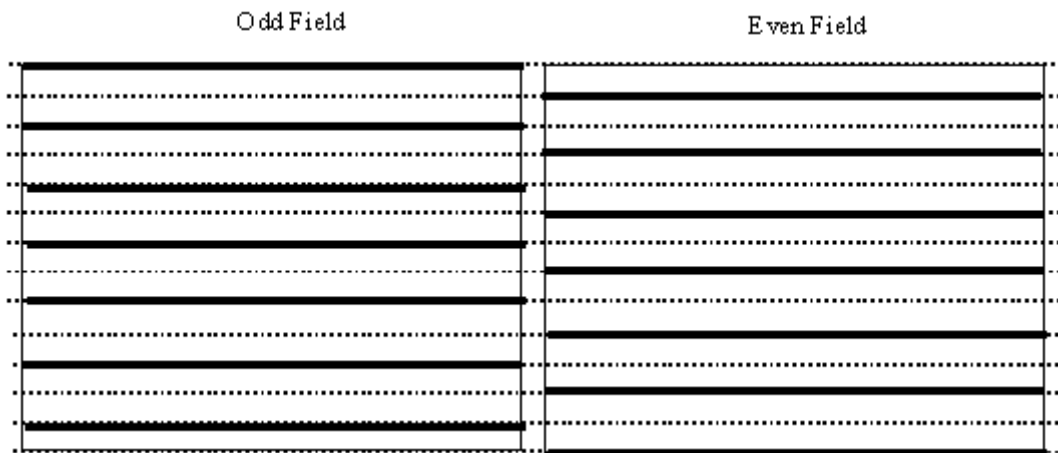

The figure above is a simplistic view of interlaced video and fields. The two fields are taken 1/60th of a second apart, and the lines of each field are not aligned, but staggered. Most televisions are interlace display devices, where the 60 fields are displayed individually and the viewer sees only one field at a time. However, most computer monitors are progressive and not interlaced display devices. On a computer monitor where video is viewed at its full resolution, viewers see both the odd and even fields at once:

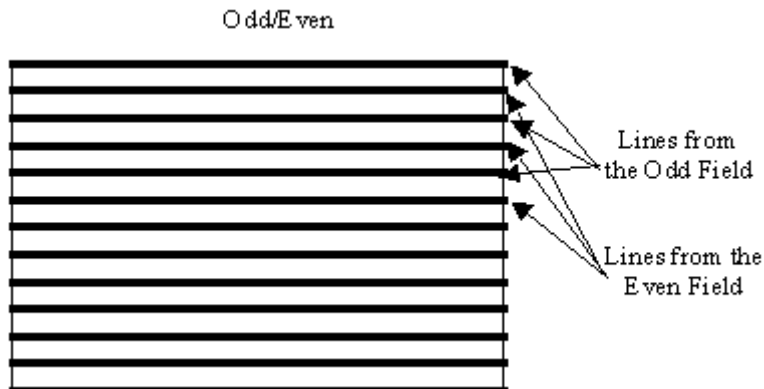

The problem with progressive display devices is that if an object is moving, its position is not the same in both the odd and even fields. When odd and even fields are merged together, interlaced artifacts occurs. The artifacts are seen and commonly described as streaking or feathering.

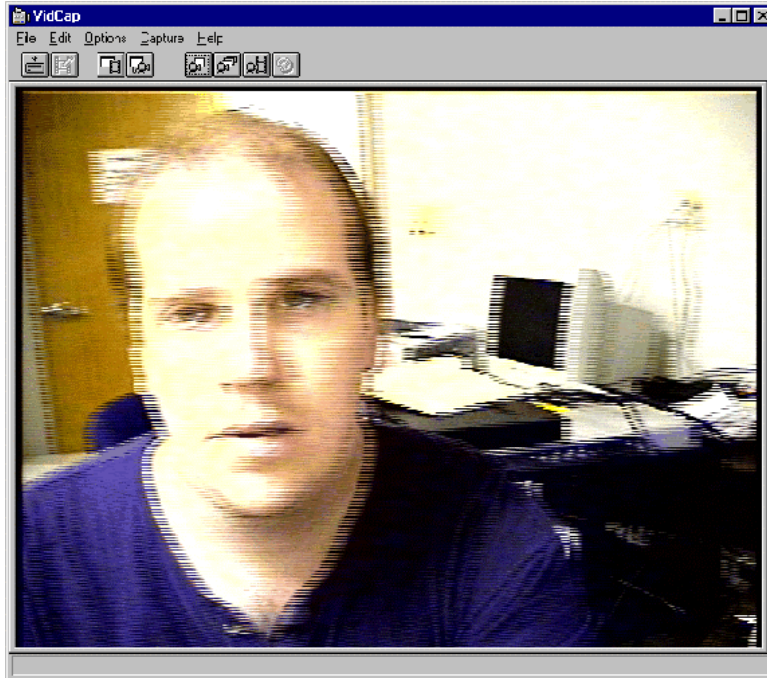

The screen above illustrates the streaking or feathering problem that occurred when the interlaced odd and even fields in this video were captured. Only a slight amount of motion took place, yet streaking is obvious in the overall result. Note the prominent horizontal lines outlining all the objects on this screen.

When feeding such images to an encoder, the encoder has a significantly harder time processing and compressing such interlaced video. The result is loss of overall quality and perhaps a loss of frame rate as well. While the encoding process may smooth out some of these artifacts, the resultant compressed video may still display somewhat streaked or feathered and may not play back smoothly.

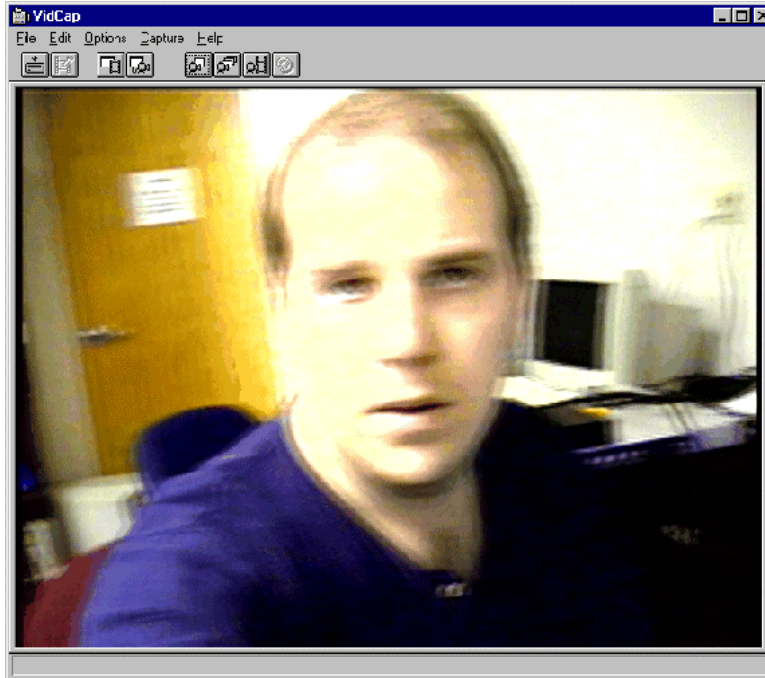

The Osprey-540's de-interlacing motion filter can be applied to any video source after to the optional scale and color-convert phases of processing to eliminate streaking or feathering and maintain motion content. In the screen above, where the Osprey-540's de-interlace motion filter has been turned on, note that the strong horizontal streaking or feathering around the subject's head have been smoothed to a slight blur. While the blur is noticeable in a single screen snapshot, the human eye perceives only natural motion when the video is played back at normal frame rates.

Feeding the de-interlaced image in the screen above to an encoder significantly improves output of the encoder in terms of overall quality and smoothness. The encoder has an easier time compressing the de-interlaced video and thus can expend saved bits and CPU cycles to produce higher quality streams.

The Transfer Mode

The Osprey-540 captures video data to the host or to the display device via two different transfer modes. The first mode, *Odd/Even*, transfers video such that the odd lines of video are grouped together before the even lines. If the video source was interlaced to start with and the hardware de-interlacing filter was not applied, the *Odd/Even* mode basically places the odd field on top of the even field. If the de-interlacing filter was applied (see description further down), this mode places the odd lines of the resultant de-interlaced frame before the even ones. The *Odd/Even* transfer mode only occurs when the resolution is greater than half the maximum resolution (>240 for NTSC and >288 for PAL).

The second mode, *Interleaved*, transfers video vertically in line order. For example, line 1, line 2, line 3, etc. Basically, this is an interlaced mode. However, since the video source may have been progressive to start with, or because the de-interlacing filter may have been applied, the term 'interlaced' transfer mode is inappropriate.

The following images further describe the *Odd/Even* and *Interleaved* transfer modes:

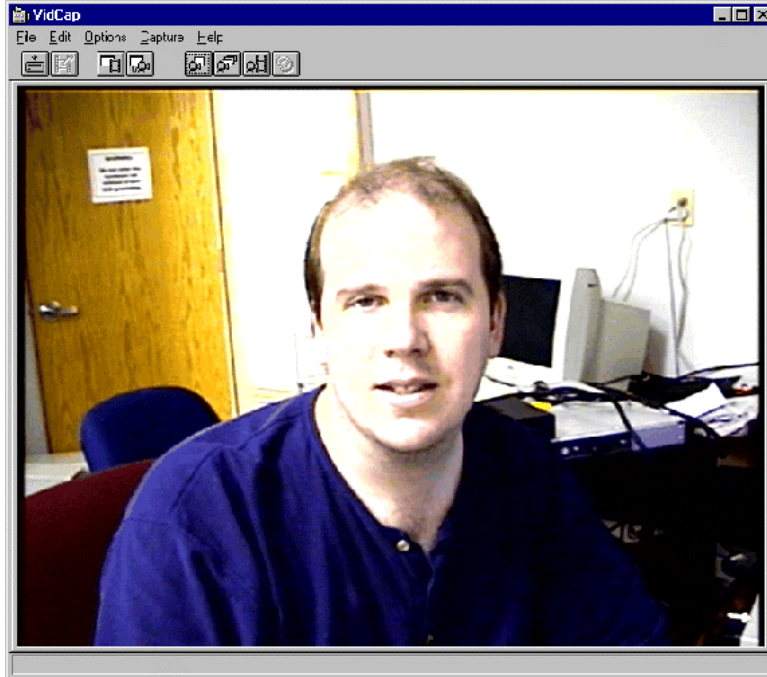

The first image is a snapshot of video captured using the *Interleaved* transfer mode. The source is an interlaced DV camera, and the image size is 640x480.

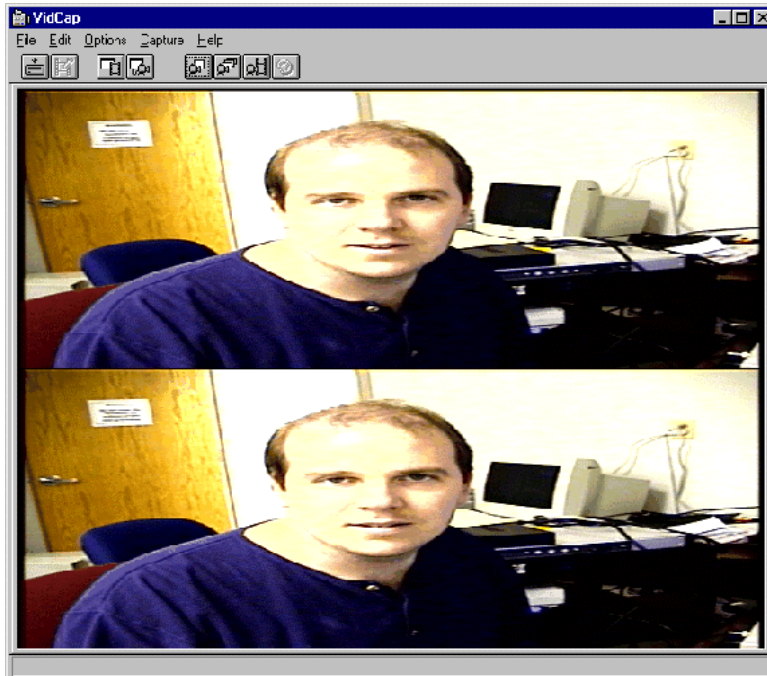

The second image is a snapshot of video captured using the *Odd/Even* transfer mode. The source is an interlaced DV camera, and the image size is 640x480.



The third image is a snapshot of video captured using the *Odd/Even* transfer mode. The source is an interlaced DV camera, and the image size is 320x480. This mode of capture can be used to acquire video at 60 fields/sec. The Osprey-540 already horizontally scaled the video down to 320 pixels in width in hardware. Having the 60 fields/sec delivered 30 times a second in the format given here offers the advantage of keeping the odd/even pairing of video consistent in the case of capture loss due to performance of the application.

The Configuration Page

The Configuration page controls several miscellaneous settings.

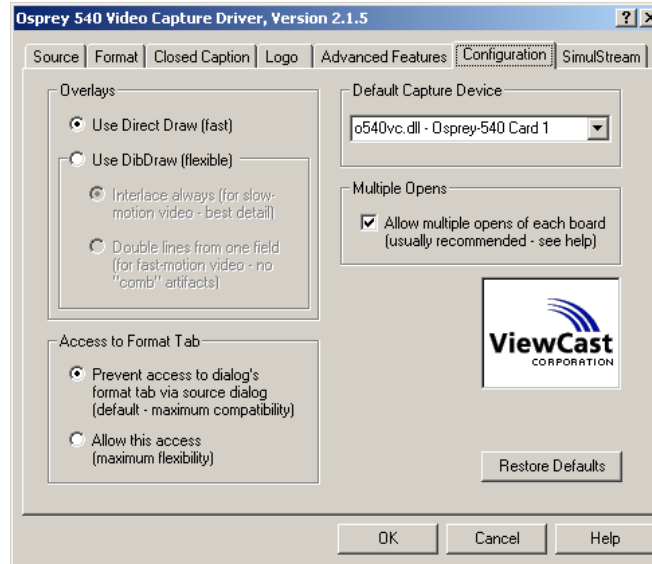

Overlays

Access to Format Tab

Multiple Opens

Default Capture Device

Overlays

Direct Draw is a fast drawing method that moves video directly from the Osprey capture card to the display adapter. If Use Direct Draw is selected, the driver uses Direct Draw for Overlay drawing. If for some reason it cannot use Direct Draw, it automatically defaults to DibDraw.

Direct Draw works with the vast majority of display adapters and software driver. We recommend running with Direct Draw enabled unless you are having a problem viewing overlay video, or want to use the "doubled lines" option discussed below. For more details on Direct Draw, refer to [Appendix E - Direct Draw](#).

DibDraw is the default drawing method. Video is moved first into system memory and copied to the display adapter. It is useful in the following cases:

1. For systems where Direct Draw does not work correctly.
2. If you want to enable "line doubling". When DibDraw is selected, two radio buttons are enabled that let you choose between interlaced and line-doubled video.

Normally, video larger than 1/2-height (240 lines NTSC, 288 lines PAL) is interlaced. NTSC and PAL video both consist of alternating odd and even fields of data. Odd numbered lines come from the odd fields, even numbered lines come from the even fields.

Interlaced video offers maximum resolution but suffers from a "comb" effect. When there is rapid motion in the video, it displays blurred. It is recommended for still or slow-motion video, but may not look good with high-motion content.

Line-doubled video uses video data from only one field. Each video line is copied to two lines of your display. Line-doubling reduces the still-picture resolution by half; however, it eliminates the "comb" effect of interlaced video and is therefore useful for viewing rapid-motion video.

3. If you want to stretch the video on your screen beyond full size (640x480 NTSC, 768x576 PAL). You would need a special application to do this. DibDraw video can be stretched but Direct Draw video cannot be.

Access to the Format Tab

The two options are:

- ◆ Prevent access to a dialog's format tab via source dialog
- ◆ Allow this access

Video for Windows applications access the Source and Format pages as separate commands and do not assume that the driver allows you to switch from one to the other.

Some applications, when they access the Source page, do not check to see if you also made changes to items in the Format page. The result is that the application and the driver may assume different settings and not work properly together.

This control in its default "prevent access" setting prevents you from entering the Source page or Closed Caption page, switching to the Format page, and inadvertently making changes that the application cannot pick up. It also disables the Board Select control on the Source and Closed Caption pages since the driver maintains separate format information for different boards. The "prevent access" setting is recommended for maximum compatibility with all applications.

The "prevent access" settings is, however, inconvenient. The alternative setting to "allow this access" allows you to switch between pages without restriction. This works with many applications; however, the responsibility lies with you to make sure no problems arise.

Multiple Opens

We recommend keeping this box checked unless you have a reason not to. This ensures compatibility with the greatest number of present and future applications that you might want to use.

If Multiple Opens is checked, a particular board can be opened for access from multiple places, either within a single process or by multiple processes. However, the features available through subsequent opens are limited. This mode is needed by certain complex applications that, for example, use separate processes for capture and overlay.

If Multiple Opens is unchecked (hunt mode), a particular board can be opened for access from only one place in one process. If there are multiple boards in the system, and an application tries to access a board that is already in use, the driver hunts for the next available board. This is the easiest way to start multiple copies of Windows Media Encoder or VidCap32, for example, to view multiple video inputs.

Changes you make take effect when you click **OK** to close the dialog. Applications such as VidCap32 do not pick up changes until you restart them.

Review [Appendix F - Multiboard Installations](#) for more information.

Default Capture Device

This control is useful if you have multiple video capture devices of different kinds. These could include cards from other vendors or different kinds of capture cards from Osprey. In this context, the Osprey-50, -100, -101, and -200 are considered one single device type. The Osprey-540, Osprey-500, the Osprey-1000, and the Osprey-2000 are each separate device types.

Some applications are capable of accessing only the primary or default device. With this control you can select which device is the default device applications use.

Changes you make are written to the registry when you click **OK** to close the dialog. Applications such as VidCap32 does not pick up changes until you restart them. Some DirectX-based applications may not detect changes until you restart the system.

The SimulStream Page

SimulStream is an added-cost upgrade option described in detail in the SimulStreaming User's Guide – Revision 1.1.

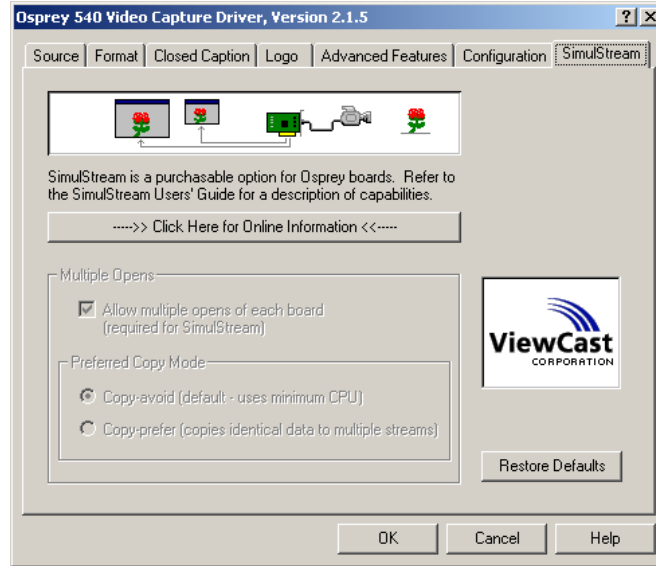

Cropping and Scaling

The Osprey video capture driver package includes the capability to crop the incoming video signal in hardware before it is encoded or captured. Cropping is done by the Osprey card and imposes no extra load on the host computer. Use any of the following methods to crop the incoming video signal:

- ◆ Video Format dialog box
- ◆ CropApp, the cropping application
- ◆ SDK

Please see the CropApp Manual which is installed in the Osprey-540 Program group for details on using this feature.

Chapter 7 - Capturing Audio

Setup and control for audio are much simpler than for video. The basic steps are covered in the following topics:

Select the Audio Source and Input Volume

Registry Settings Controlling other Audio Parameters

Audio Formats

Missing Digital Audio Sources

Audio Playback

Note for DV users:

The Osprey-540 is capable of converting sampling rates from a higher sampling rate to a lower sampling rate. For instance, if you set your DV audio to 48 kHz, the card can provide all common sampling rates (48 kHz, 44.1 kHz, 32 kHz, 22 kHz, 16 kHz, 11 kHz, 8 kHz). If your DV audio is set to 32 kHz, the Osprey-540 driver can convert to higher sampling rates.

Note for DVD users playing CD audio:

If you are playing a CD in a DVD player, the Osprey-540 is able to capture at all sampling rates including 48 kHz. This is because the Osprey-540 driver can convert audio from a lower sampling rate to a higher sampling rate.

Selecting the Audio Source and Input Volume

The audio source is set using the Osprey-540's VFW mixer driver interface. Some applications interface to the mixer driver directly and expose the look and feel specific to that application. However, there is a DirectShow based mixer interface that does **not** work with the Osprey-540's VFW mixer. If you are having problems setting mixer settings (audio ports or gains), please contact support@viewcast.com and we'll help you resolve that issue.

The default Windows interface to the mixer driver can also be used and is the recommended way to set audio ports and gains on the Osprey-540. There are two simple methods for getting to the mixer source and volume control dialog box.

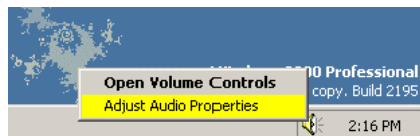

1. The easiest method for accessing this interface is to right click the **speaker symbol** on your taskbar (typically on the bottom right-hand side of your screen). Then select the **Open Volume Controls** option.
2. If you do not see the speaker symbol, click the **Start** button on the Start Menu, select **Programs->Accessories->Entertainment (or Multimedia)** and select **Volume Control**. For Windows XP, select **Start -> All Programs -> Accessories -> Entertainment -> Volume Control**.

Either of these two methods brings forth the audio mixer interface for the audio playback device. To get to the Osprey-540 audio capture (recording) device, select **Properties** under the **Options menu**. This pops up a dialog to select the **Mixer device**. Do not select the Recording option within the **Adjust Volume for** section; this option is selected automatically when you select the Osprey-540 for the mixer device. Click on the dropdown list for **Mixer device** to see the list of audio input and output devices, including the Osprey-540.

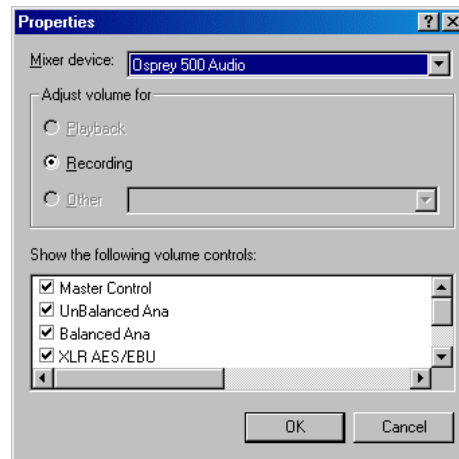

If more than one Osprey-540 card is in the system, each Osprey-540 card is enumerated individually. Once an Osprey-540 device has been chosen, select **OK** in the *Properties* dialog box.

The Osprey-540 Master Control panel displays.

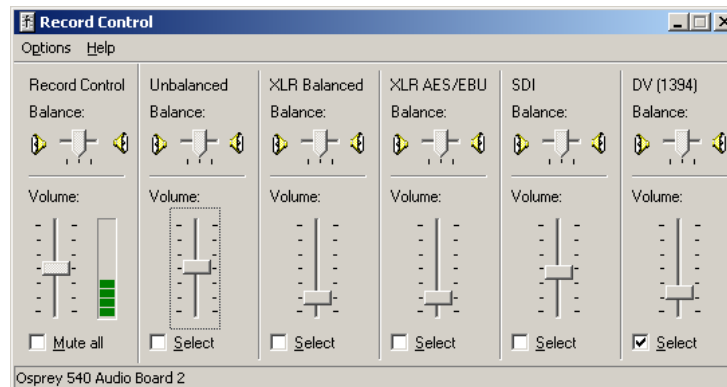

The Osprey-540 device is not a mixer in that it does not allow for mixing the various audio sources. Therefore, when one audio input is selected, any other input previously selected becomes unselected. The **Select** checkbox at the bottom of each source sets which source is actually being used. DV audio signals are embedded in DV video signals. If you select DV audio, the **video signal** selection for PAL/NTSC must match the state of the DV source.



The Osprey-540 device is not a mixer in that it does not allow for mixing the various audio sources. Therefore, when one audio input is selected, any previously selected input is unselected.

When you are capturing audio, the vertical field in the Record Control Volume section will light up with green, yellow, and red bars (like sound meters on home audio equipment).

The Osprey-540 card has a **hardware gain** on the analog audio inputs. To control the hardware gain for the card, use the volume slider in the mixer applet. The Osprey-540 card has a **software gain** control on the digital audio inputs. For instructions on changing the software gain (for digital sources only), refer to Gain Selection.

The Osprey-540 provides external monitoring of the audio input. The audio output is a stereo unbalanced RCA connector. There is no gain or attenuation control for the audio-out monitoring feature. You cannot change the balance or volume controls on the Osprey-540 playback device in the mixer applet.



The quick-access volume control (left click on the **speaker symbol**) on the task bar controls playback volume and recording volume. To change record levels, go to **Options**, then **Properties**, and select **Recording**.

Registry Settings Controlling other Audio Parameters

The Osprey-540 mixer applet does not provide a mechanism for setting all of the audio capabilities. Entries in the registry control include:

Rate Conversion Method

Gain Selection

Rate Conversion Method

This feature selects the method Osprey-540 uses to convert audio from one sampling rate to another. For example, audio from a DV source is typically 48 KHz stereo audio. For various reasons, you may want to capture audio at only 8 KHz. For most purposes, the default setting of Filter Converter works well.

The registry values which control Rate Conversion are listed below. The X stands for the device number of the Osprey-540 card. Numbering starts at 0, so the first Osprey-540 card is Device 0.

HKEY_CURRENT_USER\Software\Osprey\Osprey2000\DeviceX\Audio\RateConversion

When Rate Conversion is:

- ◆ 1 - use filter converter (default)
- ◆ 2 - use skip converter (skips samples)
- ◆ 3 - use Microsoft PCM method

Gain Selection

Gain Selection allows you to boost the audio level in software. This applies only to digital audio sources (AES/EBU, DV, and embedded SDI). Analog audio sources (unbalanced and balanced audio) have hardware gain, controlled by the volume slider on the mixer applet).

The default value of 2 is sufficient for recording from most sources including camcorders, CD players, and Walkman radios. If you have audio sources that are at lower levels, increase the Gain value. The registry values which control this are below. The X stands for the device number of the Osprey-540 card. Numbering starts at 0, so the first Osprey-540 is Device 0.

HKEY_CURRENT_USER\Software\Osprey\Osprey2000\DeviceX\Audio\Gain

The default value of Gain is 2. Set it higher for increased software audio gain. Set it below 2 to decrease gain.

Audio Formats

The only Format that the Osprey-540 audio capture driver supports is PCM. The driver supports the following data rates:

- ◆ 8 kHz
- ◆ 11.025 kHz
- ◆ 16 kHz
- ◆ 22.05 kHz
- ◆ 32 kHz
- ◆ 44.1 kHz
- ◆ 48 kHz

These data rates are supported in 8-bit and 16-bit, mono and stereo formats. The actual Osprey-540 hardware supports sampling of analog audio at 32, 44.1 and 48 kHz. Depending on the requested audio format, the Osprey-540 driver automatically selects the most appropriate hardware sampling rate. For example, if 22.5 kHz audio is desired, the audio driver selects the 44.1 kHz audio rate and down samples it to 22.05 kHz.

The Osprey-540 driver provides for optimal rate conversion from these base sampling rates. For digital sources, the sample rate has already been determined. The Osprey-540 automatically determines the digital audio sample rate and converts this as required by the application's requested sample rate.

It should be noted that the Osprey-540 does not currently dynamically readjust sampling rates while audio capture is in progress. Thus audio capture should be stopped and restarted whenever the audio input port changes.

For mono sources, the Osprey-540 uses only the left audio channel. Optionally, this can be configured to be the left channel or a mix of the left and right channels.

Missing Digital Audio Sources

Be sure to start the audio source before attempting capture. When a digital audio source (such as DV or AES/EBU) is selected before the audio is turned on, the Osprey-540 is unable to determine the sampling rate. The sampling rate is a measure of the amount of binary data needed to reproduce the audio being capture. If the audio source is not available, the Osprey-540 cannot determine the format of the incoming audio.

When a capture is started before the audio source is selected, the audio may not be sampled at the correct rate. Audio sampled at an incorrect rate sounds slower or faster than normal when it is played back. Should this occur, stop and restart capturing audio.

The default digital audio sampling rate is 48 kHz. Some common sampling rates are:

- ◆ 48 kHz (typical for SDI)
- ◆ 44.1 kHz
- ◆ 32 kHz or 48 kHz for DV sources

Audio Playback

The Osprey-540 provides audio capture only, not audio playback. Continue to play back captured audio using your system soundcard.

Chapter 8 – VidCap32, AmCap, and Included Demo Programs

The Osprey-540 Driver includes the following applications:

VidCap32

Playback

AmCap

Control Panel

DirectXMedia Details

Ligos Technology's Indeo

Cropping and Scaling

VidCap32

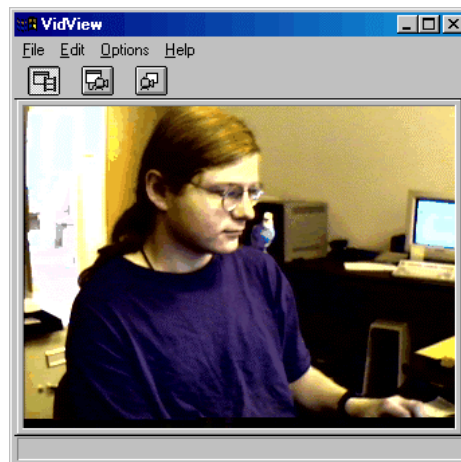

VidCap32 is a video capture application that is included with the Osprey package. It is useful for testing the installation and for general purpose viewing of video. The following instructions take you through the basic scenarios for using this applet. Also see [Cropping and Scaling](#).

Preview

Overlay

Single Frame Capture

Configuring the Video Capture Driver

Compression

Setting the Capture File – Preallocating and Defragmenting

Capturing Video

Preview

The **Preview** button (first button on the left on the toolbar) toggles Preview mode on and off. When Preview is enabled, the video you see is constantly updated and has the exact format and appearance of uncompressed video capture.

Overlay

The **Overlay** button (second button from the left on the toolbar) toggles Overlay mode on and off. When Overlay is enabled, the video you see is updated constantly. The difference from Preview is that the Osprey driver uses the fastest and most efficient drawing method it can. Normally, with Direct Draw enabled and working, it draws at the full frame rate (30 per second) with minimal processor overhead.

Note that the Preview and Overlay buttons behave like radio buttons that cancel each other - you do not have to shut off preview in order to start overlay.

Single Frame Capture

The rightmost button on the toolbar is used to capture a single frame. Every time this button is selected, a single frame is captured and displayed in the window. You can copy this image and paste it into other applications.

Configuring the Video Capture Driver

You can go through VidCap32 to access the Osprey driver's Control Dialog (described in **Chapter 6**). The menu selections **Options->Video Source...** and **Options->Video Format...** access the Control Dialog's Source and Format pages respectively. The selection **Options->Video Display...** accesses the Closed Caption page.

Compression

It is possible to compress video as it is captured to disk. Neither VidCap32 nor the Osprey video capture driver perform video compression themselves. However, VidCap32 may be connected to external software-based compression modules. Compression results in a much smaller capture file. The downside is that many types of compression are slower: you may have to reduce your frame rate in order to avoid dropping an excessive number of frames. With a “quick-compression” methods running on a fast machine, however, the extra processing time is slight enough that it is fully compensated for by the reduced time needed to write the more compact data to disk.

When a compressor is enabled, video is passed from the Osprey capture driver to the compressor, which then writes it to file. The compression dialog, accessed by the **Options->Compression** menu item, allow you to select a compressor, or select no compression. The information below for Ligos Technology’s Indeo compressor gives a detailed example of how to perform this task.

Note that the list of available compressors is different for each video Color Format selected in the Osprey video capture driver’s control dialog. You should therefore select the Color Format you are using first, then select the compressor. Otherwise, you may get an error message when you try to begin video capture.

Setting the Capture File - Preallocating and Defragmenting

The leftmost button on the toolbar (or the menu item **File -> Set Capture File**) opens the Capture File dialog box.

Depending on a number of factors, you may experience a significant percentage of frames dropped. The percentage of frames dropped is a function of frame size, use of a compressor, and the speed of your system. Performance can be substantially improved by preallocating a capture file and defragmenting it.

“Preallocating” a file means that space has been reserved for it on your hard disk. The menu item **File -> Allocate Disk Space** brings up a dialog in VidCap32 by which you can preallocate a file and reserve space large enough to hold the largest video clip that you are likely to want to capture. In AmCap, it is the menu item **File -> Allocate File Space**. You can preallocate multiple files to hold multiple video clips.

For preallocation to be useful, the hard drive should be defragmented afterwards. “Defragmenting” a drive reorganizes its physical sectors so that each file occupies contiguous sectors, rather than having different parts of it scattered about the disk.

AmCap and VidCap32 do not perform defragmentation; a third-party program is required. Various defragmentation programs are available commercially, and if you have Windows 95/98 on the system you can use its built-in defragmenter. Use AmCap or VidCap32 to preallocate the files, then exit to run the defragmentation program.



NOTE: Defragment *after* you allocate and size the capture files.

After the disk is defragmented, return to AmCap or VidCap32. The files you preallocated are now located in a contiguous areas of the hard drive. Their physical layout remains the same until the file is resized or deleted.

An alternate technique that avoids the need for defragmenting is to set up a separate disk partition dedicated to video capture, containing a single capture file.

Defragmenting is a time-consuming procedure, but is worth the trouble if you have an ongoing need to capture high-quality video, particularly uncompressed video. Be sure to plan the number and size of files you need. Once you have the defragmented files, be sure not to accidentally delete them - think of them as your permanent working space for time-critical operations, not as containers of specific video clips. Copy your clips to other files for storage and editing.

Capturing Video

The second button from the right opens the Video Capture Dialog. This can also be accessed by the **Capture -> Video** menu item.

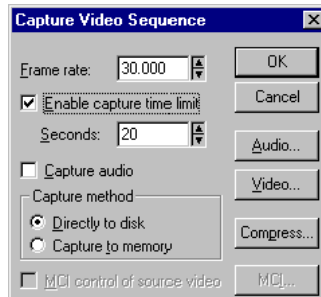

The dialog includes controls to set the number of frames per second, as well as an optional time limit (in seconds) for the sequence. Buttons are provided to access both the video capture driver's configuration dialog and the compression dialog. You can also access and configure audio, assuming that it is installed and enabled. The dialog allows a choice between capturing video directly to disk, or capturing via memory. Note that capturing to memory *may* result in fewer dropped frames - but not necessarily.

For best quality video capture, use a capture rate (frames per second) that is slow enough so that there are no dropped frames.

Once the proper configuration is confirmed, click **OK** to capture the video. To end capture, click the mouse anywhere in the VidCap32 window.

Playback

The simplest way to play back a video clip is to find its icon in “My Computer” and double-click on it. This starts Windows Media Player, which automatically plays the clip. Windows Media Player contains standard start, stop, and pause buttons and is largely self-explanatory. Refer to Windows Media Player’s online help for more information.

AmCap



AmCap is a video capture application included with the Osprey-540 package. It is useful for testing the installation, for general purpose viewing of video, and for capturing video to a file. AmCap differs from the other general purpose capture application, VidCap32, included with the Osprey package in that:

- ◆ Because AmCap captures AVI 2.0 files, AmCap can handle captured file sizes that exceed VidCap32's 2GB limit.
- ◆ AmCap is written using the DirectShow API; VidCap32 is written using the VFW API. Another application that uses DirectShow is Windows Media Encoder.
- ◆ AmCap does not support software compression modules.
- ◆ AmCap's Preview mode is equivalent to VidCap32's Overlay mode.
- ◆ AmCap does not have an equivalent to VidCap32's Preview mode.

AmCap requires the DirectX Media runtime version 6.0 or later in order to run. This runtime is included on this CD, and can be installed by the Osprey installation program. More information about DirectX Media is available at [DirectX Media Details](#).

Instructions for using AmCap are provided in the following sections. Note that this applet has additional capabilities and settings that are beyond the scope of this brief introduction. Refer to AmCap’s Help menu for a description of those capabilities and settings.

[Selecting the AmCap Device](#)

[AmCap Preview](#)

[Configuring the Video Capture Driver in AmCap](#)

[Setting the Capture File in AmCap - Preallocating and Defragmenting](#)

[Capturing Video with AmCap](#)

[Playback](#)

Selecting the AmCap Device

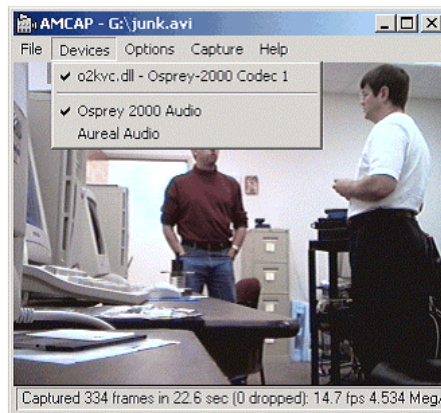

AmCap requires selecting the input device(s) before you can preview or capture video. Use menu item **Devices** to show a dropdown list of the audio and video capture devices present. In this list, the video device portion of Osprey-540 cards appears as **Osprey-540 Codec** and the audio device on the Osprey-540 displays as **Osprey-540 Audio**.

If you have multiple Osprey-540 cards present, you can select the audio device from this list. For instructions on selecting among multiple video sources, please see [The Format Page](#).

Multiple board installations are a specialized subject discussed in [Appendix F: Multiboard Installations](#).

AmCap Preview



When you first start AmCap, there is nothing in the video field display. To see video, you must enable **Preview** mode by clicking on the menu item **Options -> Preview**.

When preview is enabled, the video you see is updated constantly. What you see is a close approximation to the appearance that uncompressed video captured to file will have. However, with the AmCap applet preview video is optimized for fast screen drawing rather than the exact capture format, possibly resulting in slight differences in the appearance of the video.

Configuring the Video Capture Driver in AmCap

You can go through VidCap32 or AmCap to access the Osprey driver's Control Dialog. The menu selections **Options-> Video Source** and **Options-> Video Format** access the Control Dialog's Source and Format pages, respectively. The selection **Options-> Video Display** accesses the Closed Caption page.

The recommended color format when capturing AmCap is "4:2:2packed". This is set in the Format Page of the Osprey driver's Control Dialog.

For more information about Control Dialog, refer to [Chapter 6 - Osprey-540 Video Control Dialog](#).

Setting the Capture File in AmCap - Preallocating and Defragmenting

The menu item **File** -> **Set Capture File** opens the Capture File dialog box.

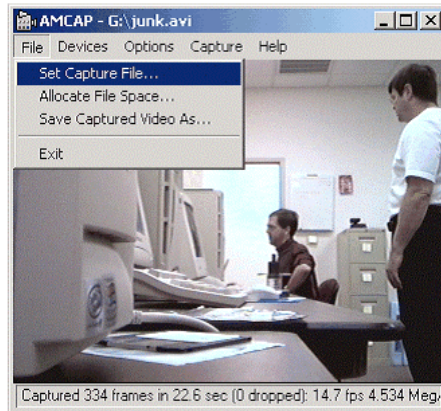

Since several variables can affect the percentage of frames dropped, performance may be substantially improved by preallocating a capture file and defragmenting it. The percentage of frames dropped is a function of frame size, use of a compressor, and the speed of your system.

If you do not know the size of file that you are going to capture, it's best to allocate a 1MB file and allow VidCap32 to dynamically allocate more space on the fly.

Preallocating a file means that space has been reserved for it on your hard disk. The menu item **File** -> **Allocate File Space** brings up a dialog in AmCap or VidCap32 by which you can preallocate a file and reserve space large enough to hold the largest video clip that you are likely to capture. You can preallocate multiple files to hold multiple video clips.

For preallocation to be useful, the hard drive should be defragmented afterwards. Defragmenting a drive reorganizes its physical sectors so that each file occupies contiguous sectors, rather than having different parts of it scattered about the disk.

AmCap and VidCap32 do not perform defragmentation; a third-party program is required. Various defragmentation programs are available commercially, and Windows 2000 contains a built-in defragmenter. Use AmCap and VidCap32 to preallocate the files, then exit to run the defragmentation program.



NOTE: Always defragment after you allocate and size the capture files.

After the disk is defragmented, return to AmCap/VidCap32. The files you preallocated will now be located on contiguous areas of the hard drive and their physical layout will remain the same until the file is resized or deleted.

An alternate technique that avoids the need for defragmenting is to set up a separate disk partition dedicated to video capture, containing a single capture file.

Defragmenting is a time-consuming procedure, but is worth the trouble if you have an ongoing need to capture high-quality video, particularly uncompressed video. Be sure to plan the number and size of files you will need. Once you have the defragmented files, be sure not to accidentally delete them. Think of these files as your permanent working space for time-critical operations, not as containers of specific video clips. Copy your clips to other files for storage and editing.

Capturing Video with AmCap

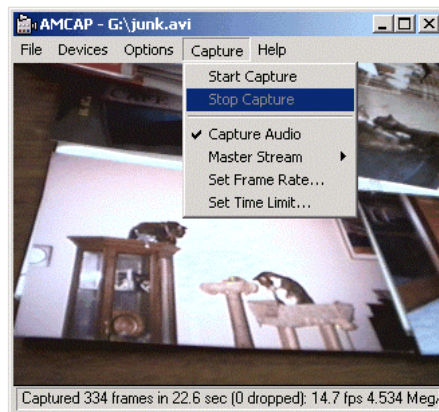

AmCap requires setting a few options before starting Video Capture.

1. First, set the Frame Rate by selecting menu item **Capture -> Set Frame Rate**

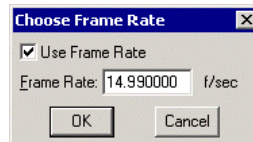

2. Note that the maximum NTSC frame rate is 29.97 frames/sec and not 30 frames/sec. The maximum PAL frame rate is 25 frames/sec. If you want to capture at the full NTSC frame rate, **set the rate to 29.97 in this menu.**
3. Capturing uncompressed video to disk is limited by disk throughput. You may find that your system is not capable of capturing to disk, for example, at full resolution full frame rate. In this case, you may be best served by reducing either the frame rate, the resolution, or both.

- If you are capturing audio, use menu item **Capture -> Capture Audio** to turn on the checkmark for audio capture.

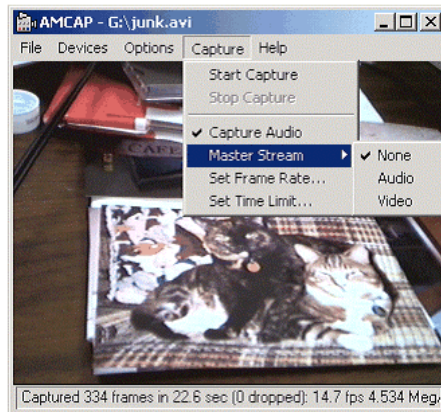

- Set the master stream for audio/video synchronization by using the control dialog brought up by **Capture -> Master Stream** to select whether **Audio**, **Video**, or **None** is the master stream for synchronization.

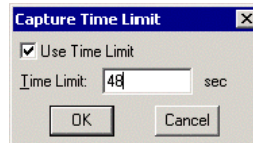

- You can optionally set a time limit on this capture through the **Capture -> Set Time Limit** dialog.
- Once the proper configuration is confirmed, click the **Capture -> Start Capture** menu item, and click **OK** on the confirmation dialog to begin capture.
- If you did not set a time limit, use the menu item **Capture -> Stop Capture** or press the **Esc** button to end your capture.

DirectXMedia Details

Microsoft® DirectX® Media is the media layer of the Microsoft® Windows® multimedia system, providing multimedia playback and capture support, image transformations, media integration, and animation for the Web and desktop.

[Information Specific to Windows 2000 or Windows XP](#)

[Information Specific to Windows NT](#)

[General Information](#)

Information Specific to Windows 2000 or Windows XP

Windows 2000 and Windows XP both already contain versions of DirectX® Media suitable for applications like AmCap and Windows Media Encoder. The Osprey-540 driver and applications like Windows Media Encoder also work with the versions of DirectX® that Windows 2000 and Windows XP install by default. If you install a third-party application which uses DirectShow, that application may direct you to install a newer DirectX® Runtime for Windows 2000 (version 8.0 or 8.1).

Information Specific to Windows NT

The DirectX® Media runtime is included on this CD, and can be installed by the Osprey installation program. See the Readme.txt file for details. DirectX® Media requires that Microsoft® DirectX® 3.0 or later be installed. Windows Service Packs 4 and later contain DirectX® 3.0. More information about DirectX and Windows NT is available at <http://www.microsoft.com/directx/homeuser/faq.asp - dx4>

General Information

More information about DirectX Media is available at:

<http://www.microsoft.com/directx/homeuser/information/dx4nt.asp>

and

[http://www.microsoft.com/directx/homeuser/downloads/default.asp - DirectX Media.](http://www.microsoft.com/directx/homeuser/downloads/default.asp - DirectX Media)

The DirectX Foundation Layer consists of Microsoft DirectDraw®, Microsoft Direct3D®, Microsoft DirectInput®, Microsoft DirectSound®, Microsoft DirectPlay®, and Microsoft DirectMusic®. Thus, DirectDraw is part of DirectX, and is another reason that a video display adapter which supports DirectDraw is desirable.

More information about DirectX is available at:

<http://www.microsoft.com/directx/homeuser/faq.asp>

and

<http://www.microsoft.com/directx/homeuser/aboutdx.asp>

The latest version of all DirectX downloads can always be found at:

<http://www.microsoft.com/directx/homeuser/downloads/default.asp>

Because DXMedia is not part of the current DirectX releases, it can be downloaded from:

<ftp://www.microsoft.com/developer/platformsdk/july2000/common/redis t/dxmedia>

The DirectX Media package is distributed with Microsoft's DirectX 7.0a SDK, which can be ordered on CD from Microsoft. The DirectX Media package has also been distributed on the Platform SDK CD in MSDN subscriptions.

Cropping and Scaling

The Osprey video capture driver package includes the capability to crop the incoming video signal in hardware before it is encoded or captured. Cropping is done by the Osprey card and imposes no extra load on the host computer. Use any of the following methods to crop the incoming video signal:

- ◆ Video Format dialog box
- ◆ CropApp, the cropping application
- ◆ SDK

Please see the CropApp Manual which is installed in the Osprey-540 group for details on using this feature.

Ligos Technology Indeo

Ligos Technology's Indeo is a software video compressor that works with the Osprey Video Capture Driver. It allows you to capture video to disk using much less disk space, at the cost of only a slight loss of picture clarity. On a 300 MHz Pentium II system you can capture 320x240 NTSC video at a full 30 frames per second with a 25:1 compression ratio.

Indeo is included on Osprey-540 driver CDs. Refer to Chapter 3 - Installing the Software - Windows 2000, Chapter 4 - Installing the Software - Windows XP, or Chapter 5 - Installing the Software - Windows NT 4.0 for installation information.

You can also download the most up-to-date version for free on Ligos' web site. As of this writing, the location is as follows:

<http://www.ligos.com/indeo/downloads/>

The file to download currently is **iv5setup.exe**. You need a version that compresses video as well as decompresses it.

Indeo Video compressor version 5.11 works with RGB24 and RGB15. It does not work with YUV12 or YVU9. However, the Indeo package does include components you can use to capture uncompressed YVU9 and 4:2:2 packed video.

Use the following steps to demo Indeo with the Osprey card:

9. Connect and adjust your video source. Start **VidCap32**.
10. Use the **Options->Format...** menu entry to bring up the Osprey driver's Control Dialog Format page. In the drop-down list in the Color Format field, select **RGB24** (or **RGB15**). Select ½ sized (CIF) video. Click **OK**.
11. Use the **Options->Compression...** menu entry to bring up the compression dialog. In the Compressor: field, select **Indeo video 5.11**.

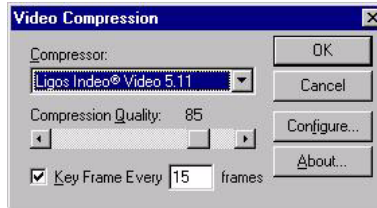

12. Before leaving the compression dialog, click the **Configure...** button. Enable **Quick Compress** in the Encoder Controls field, and click **OK**.



NOTE: If you do not enable Quick Compress, compression is *much* slower. Click **OK** again to close the Video Compression dialog box.

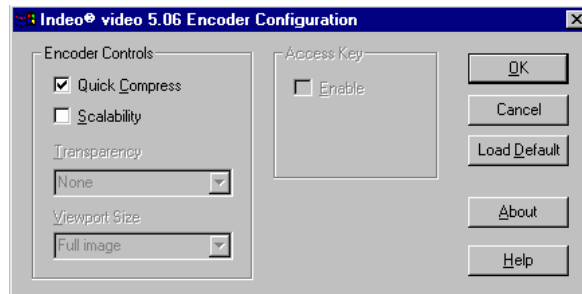

13. Select **Set Capture File..** under the File menu. Set the name that you want for the file that contains the captured video. Click **Open**.
14. Select **Capture->Video**. Select 30 frames per second for NTSC or 25 for PAL/SECAM. Click **OK**. A confirmation dialog displays. Click **OK** again to start capturing video.
15. Click anywhere on VidCap32 when you want to end capture
16. Open **My Computer** and navigate to the icon of the file you just captured. Click on it and it plays back.

If you experience more than one or two dropped frames, use a lower frames per second capture rate. Useful rates for NTSC video are 30, 15, 10, and 7.5; for PAL/SECAM, 25, 12.5, 8.33, and 6.25.

Indeo has numerous options. You can obtain higher quality video and more compression options by capturing uncompressed video and then compressing it off-line.

Control Panel

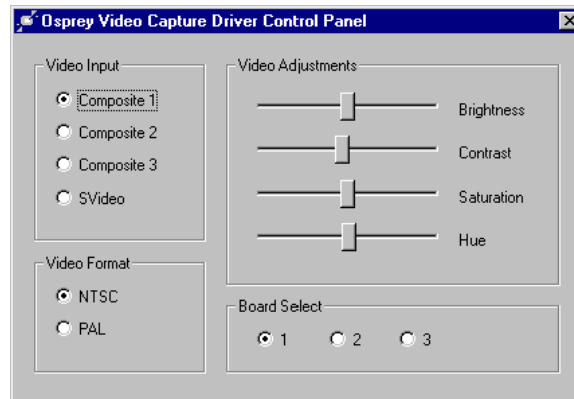

The Osprey video capture driver package includes a Control Panel application that allows you to control the video source while another application is running. Some applications make it hard or impossible to access the driver's control dialogs while they are running. The Control Panel allows you to make these adjustments without closing and restarting the primary application.

Video Input

Video Format

Video Adjustments

Board Select

Video Input

The Video Input field controls which of the board's physical inputs to use. The list of available inputs may vary from the illustration depending on the exact hardware you have.

Video Format

The Video Format field indicates whether NTSC or PAL video is selected and allows you to change the format. NTSC is the video standard in North America and Japan. PAL is the standard in most European countries, and many other countries as well. Please see the section [Video Standard](#) for additional information.

Video Adjustments

The Video Adjustment sliders allow you to interactively control the brightness, contrast, saturation, and hue of the video being captured or displayed by the primary application. PAL video does not have a hue adjustment.

Board Select

The Board Select field is displayed and used only when there are multiple Osprey cards installed in the system. The buttons of this field determine which of two, three, or four boards is currently being controlled.



NOTE: These buttons affect which board is being controlled, not which board the application is connected to. Their action is therefore slightly different from the Board Select controls in the driver's internal Setup Dialogs.

Chapter 9 - Troubleshooting

Blue/Pink/Black/Orange Video Screen

Black Preview Video Screen

Scrambled Video Image

Grainy, Dithered Image

Slow Overlay Drawing

Problems Using Direct Draw

Poor Video Quality at Large Frame Sizes

Wrong Capture Driver Being Accessed

Unwanted Closed Caption Text

No Closed Captions on Digital Video

Interrupt Conflicts

Multiple Horizontal Lines Across Video Image

Cannot Play Back Audio Recorded by the Osprey-540 Card

Video Control Dialog Windows are Empty under WinNT

Blue/Pink/Black/Orange Video Screen

The currently selected video input is not receiving an active video signal. Different inputs may provide a different symptom when a video source is not supplied. For example, with the Osprey-540, if no DV source is connected to the card, the DV video may display as a solid pink screen. While playing a tape in a DV camcorder, you may see an orange screen at end-of-tape. Video from composite/S-video may display as a black screen (maybe with a single horizontal line in it). If no SDI source is connected, the video will appear as a solid green field.

1. Check that the camera, VCR, or other video source is powered and that its output is connected to the Osprey card's input.
2. Check that the correct video input is selected in the Control Dialog's Source page.

Black Preview Video Screen

If you select a Color Format other than one of the RGBs or Grey8, you may get a black preview screen. You may also get a message such as "Error: Unable to draw this data format". The problem is that Video for Windows does not know how to decode these more specialized formats. It must be able to locate a software video decompressor on your system that works with this format.

If you encounter this situation with a Color Format that you need or want to use, you have to obtain a suitable compressor. For example, if you install Ligos Technology's Indeo compressor you can preview the YVU9 format. To download from Ligos's web site:

<http://www.ligos.com/indeo/downloads/>

Scrambled Video Image

You may have set the wrong video signal format for the signal input you are using. For example, you may have told the driver to look for NTSC-M video but are using a PAL-BDGI video source. Make sure you know what signal format your video source is generating. Go into the **Signal** field of the Control Dialog's Source page, and click the button for that signal format.

Grainy, Dithered Image

Check that you are using a display format with greater than 256 colors. If a 256 color format is used, the system can only approximate the actual colors, and does so with a loss of resolution and precision.

Slow Overlay Drawing

You should be able to obtain 30 frames per second with minimal processor loading by enabling Direct Draw. System requirements for realizing this speed are:

- ◆ a video display card that supports Direct Draw
- ◆ a video display device driver for the card that supports Direct Draw

Either or both of the two checkboxes in the Direct Draw field of the Control Dialog's Configuration page must be checked.

Refer also to [Appendix E - Direct Draw](#).

Problems using Direct Draw

Direct Draw is a recent technology and it is possible that you may have problems using it with your particular combination of display adapter, display driver, and machine. Any problems should arise only when Overlay mode screen drawing is in use; the Osprey card does not use Direct Draw at other times. If you do have problems, disable either or both Direct Draw methods by unchecking their boxes in the "Direct Draw" field of the Control Dialog's Configuration page. We have seen problems with Secondary Direct Draw on a few older display adapters. Refer also to [Appendix E - Direct Draw](#), for more details.

Poor Video Quality at Large Frame Sizes

Large frame sizes with the deep pixel depth (24- or 32-bit), or complex format (YVU9 or YUV12 planar), impose heavy demands on the PCI bus's data transfer capacity. Our experience is that some systems cannot handle these formats at full frame sizes.

Systems vary in their data transfer limits. The characteristics of the PCI bridge are often more important than processor speed. If you are having problems, we recommend that you:

- ◆ Use a smaller frame size (480 x 320 or less).
- ◆ Use a shallower color format (RGB15 or RGB24 instead of RGB32).
- ◆ Try an RGB format instead of a YVU format, and a packed format instead of a planar format.
- ◆ If you have a choice of PCs for video capture, try using another system with a different system board chipset.

Wrong Capture Driver Being Accessed

This might happen if you already had another capture board/capture driver on your system when you installed the Osprey card. The Osprey installation procedure allows you to set the Osprey driver as either the primary or secondary video capture driver. [Appendix D - Using the Osprey Video Capture Driver with Other Video Capture Drivers](#) gives a full description of how to set the Osprey driver as the primary driver.

Some applications, including VidCap32, allow you to select which video capture driver to use. In VidCap32, a list of installed video capture drivers is appended to the bottom of the **Options** menu.

Unwanted Closed Caption Text

Closed Caption text consists of white or colored characters drawn on black character cells.

In video that contains Closed Captioning information, the first active line of video in each field contains encoded Closed Caption text. In video that does not have Closed Captioning information, that line is simply ordinary video.

If you leave Closed Captioning enabled and view non-Closed Caption video, the Osprey video capture driver attempts to interpret the first line of each field of video as Closed Caption character codes. Some video may display sufficiently similar to Closed Caption data that the software thinks it is Closed Caption text. The result is occasional randomly drawn text appearing on the screen.

The solution is to turn off Closed Captioning when you are viewing sources that are not Closed Captioned. To do so, open the Control Dialog's Closed Caption page and uncheck the **Enable** box in the Display field. The change takes effect when video is restarted after exiting the dialog.

For more information about Closed Captioning, refer to [The Closed Caption Page](#).

No Closed Captions on DV or PAL Video

The Osprey-540 is capable of decoding closed captions on NTSC video inputs. This feature is supported on SDI and analog video sources - the composite and S-video inputs, and digital SDI, only. It is not supported on the DV input.

Interrupt Conflicts

Failed network connections, failure of a device drive to initialize during start-up, or failure of the Osprey card and driver to operate properly are often traced to interrupt (IRQ) conflicts. In our experience, IRQ conflicts are most commonly seen when a PCI SCSI adapter, or possibly a PCI network adapter, is present in the system.

[Conflicts Between PCI Cards](#)

[Conflicts of PCI Cards with ISA Cards](#)

Conflicts Between PCI Cards

PCI cards and drivers do not choose which IRQs they use; rather, the operating system assigns IRQ lines to PCI cards. The IRQ configuration for the Osprey card or cards is determined by Windows NT, and the Osprey driver cannot change this configuration. However, you can cause the operating system to assign IRQs differently by rearranging cards or changing BIOS settings.

Multiple PCI cards are supposed to be able to share the same IRQ line. In practice, occasionally you may encounter a device driver that is not implemented correctly for interrupt sharing. If this problem arises, you have to rearrange the PCI cards so that the non-compliant card does not share its IRQ line with any other device.

Another problem is that some PCI device drivers expect to use a particular IRQ line. When a new card is added, it causes the system to assign IRQs differently. If the IRQ assignment for a particular card is changed and its device driver does not detect the change, this causes the system to work incorrectly.

The simple answer to this problem is it can sometimes be solved by physically rearranging the PCI cards such that their arrangement in the PCI slots is different. When doing this, keep careful notes of the arrangements you have tried.

Another approach to PCI card conflicts is at the BIOS level. Depending on what kind of system BIOS you have, you may be able to change which IRQ lines are allocated to PCI devices versus ISA devices. You may be able to allocate more IRQ lines for PCI devices and thereby solve a PCI conflict.

If these approaches do not work, see Getting Help in [Chapter 1](#).

Conflicts of PCI Cards with ISA Cards

A PCI card and an older-style ISA card can never share IRQ lines. Windows NT cannot detect with certainty what IRQ line an ISA card is using and cannot always prevent the conflict.

You can view the system's IRQ assignments by running the Windows NT Diagnostics program in the Administrative Tools menu or program group. Select the **Resources** tab and click the **IRQ** button at the bottom of the field. If the list of cards shows an ISA card using the same IRQ as another device, the conflict should be resolved by changing the IRQ of the ISA card.

Unfortunately, if a device driver for an ISA card has failed to initialize because of an IRQ conflict, the card's IRQ does not display in the list. To find the conflict, you have to examine all your ISA cards with the Control Panel to find out what IRQs they are trying to use.

Multiple Horizontal Lines Across Video Image

If there are multiple, regularly spaced, horizontal lines across your video image and your source material is copyrighted and copy-protected, you are seeing Macrovision™ copy protection. It looks like this:



The lines can vary in color from yellow to blue to green. These lines are not present in every frame of video. There may also be a black band at the top of the frame.

The Osprey-540 cannot eliminate these video artifacts. These artifacts are only present when you are using a copy-protected source, such as a high-quality DVD for testing a card.

Cannot Play Back Audio Recorded by the Osprey-540 Card

If you have a sound card installed, you should be able to hear audio when you play back recorded audio.

- ◆ Verify that the volume control for your playback device is not muted.
- ◆ Verify that the selected playback device is your sound card, and not the

Osprey-540 Placeholder device. The Placeholder device exists in order to handle the situation where there is an Osprey-540 present without a sound card. Some Windows applications cannot use a recording device unless a playback device is also installed. The Placeholder device cannot play back recorded audio. You can use the same method to select playback device that you use when selecting the audio source.

Video Control Dialog Windows are Empty under WinNT

This problem occurs only for Windows NT installations that are running Service Packs earlier than SP4, or that are running versions of Internet Explorer earlier than version 4. The problem is caused by the Osprey driver software's use of features (window dialog controls) provided by Windows NT that were introduced in 1999.

This problem can be fixed by:

- ◆ applying NT Service Pack 4 or later.



Service Pack 6a is required to use Microsoft's Windows Media Encoder 7.1 and Media Player 7.1.

-
- ◆ installing Internet Explorer version 4 or later
 - ◆ downloading and installing the latest version of 401Comupd.exe from Microsoft's website at <http://www.microsoft.com/msdownload/ieplatform/ie/comctrlx86.asp>

Appendix A - Hardware Specifications

The physical specifications for the Osprey-540 Capture Cards are as follows.

Table A-1 Physical Dimensions

Length	133 mm
Width	22 mm
Height	121 mm
Weight	63 grams

Table A-2 Environmental Specifications

Operating temperature range	0° to 40° C
Non-operating temperature range	-40° to +75° C (RH)
Operating humidity range	Between 5% and 80% (non-condensing) @ 40° C
Non-operating humidity range	95% RH (non-condensing); gradient 30% per hour
Operating altitude range	0 to 3,048 meters (10,000 feet)
Non-operating altitude range	0 to 15,240 meters (50,000 feet)

Appendix B - Color Modes

The Color Format field of the Control Dialog's Format page allows you to select the following video formats.

RGB32 - Each pixel has four bytes (32 bits) of data - one each for red, green, and blue, plus one byte of padding. The pixel has 256 shades of each of the three colors, for a total of 16.7 million colors. This is a "true color" mode.

RGB24 - Each pixel has three bytes (24 bits) of data - one each for red, green, and blue. This is another "true color" mode with 16.7 million colors, and is a recommended format for capturing images with the highest possible color accuracy.

RGB15 - Each pixel has two bytes (16 bits) of data. There are 5 bits each of red, green, and blue data; the sixteenth bit is unused. This is a "high color" mode, also known as "5:5:5."

Grey8 - Each pixel has one byte of data, representing one of 256 greyscale levels.

4:2:2 packed - Also known as **YUY2**. This mode represents each pixel with a total of 2 bytes (16 bits) of data. The data is encoded as separate data for luminance (intensity) and chrominance (color). This mode is mainly used as an input to software compressors. See below.

YUV12 planar - Also known as **I420**. This is a complex format in which there are in the aggregate 12 bits of data per pixel. Each pixel has 8 bits of luminance data. Each group of 4 adjacent pixels shares two bytes of chrominance data. See below.

YVU9 planar - Similar to YUV12 planar, except that there are in the aggregate 9 bits of data per pixel, and each byte pair of chrominance data is shared by 16 adjacent pixels.

YUV Format Details

YUV Format Details

4:2:2, YVU9, and YUV12 are YUV formats. In these formats, each pixel is defined by an intensity or luminance component, Y, and two-color or chrominance components, U and V. Since the human eye is less sensitive to color information than to intensity information, many video formats save storage space by having one luminance byte per pixel while sharing the chrominance byte among two or more pixels. YUV is also very similar to the color encoding used for analog color television broadcast signals.

4:2:2 packed mode consists of a single array of mixed Y, U, and V data. Each pixel has one Y (intensity) byte. Each pixels shares its U and V bytes with one of the pixels horizontally next to it:

Pixels 1 and 2:

byte 1 = y_1 byte 1 intensity

byte 2 = $u_{1/2}$ shared U color information for bytes 1 and 2

byte 3 = y_2 byte 2 intensity

byte 4 = $v_{1/2}$ shared V color information for bytes 1 and 2

Pixels 3 and 4:

byte 5 = y_3

byte 6 = $u_{3/4}$

byte 7 = y_4

byte 8 = $v_{3/4}$

4:2:2 packed mode uses the same number of aggregate bytes per pixel as RGB15, which is two. However, 4:2:2 is more efficient than RGB15 because it stores relatively more of the intensity information to which that the human eye is most sensitive.

YVU9 and **YVU12** are "planar" modes - the Y, U, and V components are in three separate arrays. It is easiest to explain the format with an example: Let's say you have a 320x240 YVU9 format. The buffer has 320x240 bytes of Y data, followed by 80x60 bytes of V data, followed by 80x60 bytes of U data. So each U and each V byte together contain the color information for a 4x4 block of pixels.

Similarly, a 320x240 YUV12 format has a 320x240 Y array, followed by a 160x120 U array, and then a 160x120 V array.



Note that in the I420 format used by Osprey, the order of the U and V arrays is reversed from the order in the YVU9 format.

Appendix C - Video Sizes

The table below gives the standard video sizes available through the Control Dialog's Format page.

The 525-line video formats are NTSC-M, NTSC-J, and PAL-M.

The 625-line video formats are PAL-BDGHI, PAL-N, and PAL-NC.

CCIR601 is a video proportioning standard that can be selected on the Control Dialog's Format page.

Available Video Sizes (Width x Height:)

	525-line (Sqr Pixels)	525-line (CCIR601)	625-line (Sqr Pixels)	625-line (CCIR601)
Full	640 x 480	720 x 480	768 x 576	720 x 576
1/2 (CIF)	320 x 240	360 x 240	384 x 288	360 x 288
3/8	240 x 180	270 x 180	288 x 216	270 x 216
1/4 (QCIF)	160 x 120	180 x 120	192 x 144	180 x 144

Appendix D - Using the Osprey Video Capture Driver with Other Drivers

If you already have a video capture driver installed in your system, the Osprey installation software offers the option of installing the Osprey driver as your primary video capture driver. A dialog box with that option displays near the end of the installation sequence.

The Windows 2000 and Windows XP installers do not offer this option.

After installation, you can change the primary video capture driver by going to the Configuration Page of the driver's setup dialog and then to the Default Capture Device option.

If the Osprey driver is set as your primary video capture driver, it automatically connects to Video for Windows applications as the default driver. If you install it as a secondary or auxiliary video capture driver, it is not be accessible to Video for Windows programs and utilities that lack a control for selecting a specific capture driver. Your other driver, however, remains immediately accessible as the default driver.

Appendix E - Direct Draw

Direct Draw is a fast on-screen drawing method. The Osprey video capture driver utilizes Direct Draw for drawing video overlays. Video overlay is a display mode available in most video capture applications, including VidCap32. It is enabled by clicking an **Overlay** button, or by selecting an Overlay menu entry. It is distinct from Preview mode. Preview mode does not utilize Direct Draw.

Direct Draw is enabled by the Direct Draw Enable checkbox on the Control Dialog's Configuration Page. When Direct Draw is enabled, the Osprey driver attempts to use it for overlays. If it cannot (e.g., the display driver does not support Direct Draw), the Osprey driver defaults to DibDraw.

When Direct Draw is used, video is copied by direct memory access (DMA) directly from the Osprey board to the visible screen memory, and video is overlaid at 30 frames per second with very low main processor utilization. When Direct Draw is not used, video is copied by DMA into system memory, and then copied again into display memory. Frame rate without Direct Draw is 30 per second for smaller frame sizes, but less for larger sizes, and processor loading is substantial.

In order to utilize Direct Draw, the following conditions must be met:

1. You have to enable Direct Draw by checking the Enable button on the Control Dialog's Configuration page.
2. Your video display card must support Direct Draw.
3. The software device driver for your video display card must support Direct Draw. It is recommended that you use the most recent driver available. The drivers on the Windows NT 4.0 CD-ROM do not support Direct Draw in all cases. You can obtain the most recent version from your video card manufacturer's web site.
4. You must be using a video format other than Grey8. The Osprey driver does not support Direct Draw of greyscale video.
5. You can tell whether the system is using Direct Draw as follows: When Direct Draw is in use, the display near the video capture window flickers when either the video capture window or an overlapping menu or window is moved. When DibDraw is being used, there is no flicker.
6. You can also measure CPU utilization using the Task Manager's performance meter. When measuring CPU utilization, first shut down any applications that might be actively consuming significant CPU time. CPU utilization is just a few percent when Direct Draw is running. If DibDraw is running, CPU utilization is substantial, especially if the image is large.

Appendix F - Multiboard Installations

The multiboard capability of the Osprey-540 Capture Driver allows both single and multiple applications to simultaneously access multiple boards. However, the driver does not allow multiple applications or processes to access a single board unless the added-cost SimulStreaming option has been enabled for the board, or another special circumstance exists.

First, some background on the logic by which the Osprey-540 driver determines connection or startup order for multiple boards. The numbering of the boards is determined by the order in which the operating system recognizes their presence in the slots in which they are installed. The arrangement of logical PCI slots is different for different machines, and you should experiment to determine which physical board is Board 1. Also, the numbering under Windows 2000 or Windows XP may differ from the numbering under Windows NT 4.0.

Every time the system is rebooted, the Osprey-540 drivers re-enumerate the boards in the system and make unique video capture entries for each board. If the **Multiple Opens** box is not checked under Access for Multiple Boards on the Configuration Page of the Osprey-540 Video Control Dialog, a "default" registry entry is made that represents the legacy method of opening multiple devices, as well as registry entries for individual boards. If the box is not checked (selecting the check box is recommended), only entries for specific cards are created.

[The Recommended Multi-Board Selection Approach](#)

[The Legacy Multi-Board Selection Approach](#)

The Recommended Multi-Board Selection Approach

The recommended method is to check the **Multiple Opens** box on the Configuration Page of the Osprey-540 Video Control Dialog. Checking this box should result in the generation of only individual device names as video capture device entries. For example, the following msvideo entries display for two Osprey-540 devices in the system:

- ◆ o540vc.dll - Osprey-540 Card 1
- ◆ o540vc.dll - Osprey-540 Card 2

These "Card 1" / "Card 2" names should be used when opening the Osprey-540. In the event that you see a "Card Default" entry (see the legacy approach below), this is for legacy applications that did not allow for specific device selection.

The Legacy Multi-Board Selection Approach

The non-recommended method is to not check the **Multiple Opens** box on the Configuration Page of the Osprey-540 Video Control Dialog. Not checking this box should result in the generation of individual device names as well as Card Default name as video capture device entries. For example, the following msvideo entries display for two Osprey-540 devices in the system:

o540vc.dll - Osprey-540 Card Default

o540vc.dll - Osprey-540 Card 1

o540vc.dll - Osprey-540 Card 2

If two or more boards are installed and you use the default device name to access the Osprey driver, it first connects to the default board. Normally, the default board is whichever board was most recently selected in the Control Dialog's Board Select field. If this default board is in use (and the MultiOpen option is turned off), the next available board is automatically selected. Once any board is selected, you can change it to a different board by selecting the desired board in the application you are using (often under a menu titled **Options** or **Board Select**).

Multiple boards may be accessed according to two main scenarios:

- ◆ *Multiple processes accessing multiple boards:* Start two standard applications - or two copies of one application - such as VidCap32. The first copy comes up connected to the default board and starts normally. The second copy automatically hunts for the next available board in ascending numerical order.
- ◆ *A single application accessing multiple boards:* A single custom application can access two or more different boards. If the standard Video for Windows interface is used, the access order is the same as described above.
- ◆ *Multiple applications accessing single board:* If you have the added-cost SimulStream upgrade, then multiple applications can access a single board. This option is described in detail in the SimulStreaming User's Guide.

Multiple Opens is much more precise and flexible for custom applications that use the Osprey Video For Windows NT/2000 Software Developers' Kit (VFW SDK). This kit allows you to override the default board in order to access any board at any time. It is recommended that developers of multiple board applications obtain this kit, described in Appendix K. Please inquire at <mailto:info@ospreyvideo.com> for more information.

Appendix G - File and Registry Usage

The following are files that are written and registry entries that are set when Osprey drivers are installed. This information allows a technically proficient user to remove the Osprey-540 installation if the uninstaller is deleted or damaged.

[Instructions for Windows NT 4.0](#)

[Instructions for Windows 2000 and Windows XP](#)

These instructions are for advanced users only!



Refer to [Chapter 3 - Installing the Software - Windows 2000](#), [Chapter 4 - Installing the Software - Windows XP](#), or [Chapter 5 - Installing the Software - Windows NT 4.0](#) to remove the software. Be careful not to delete or alter any items other than the ones described here!

Instructions for Windows NT 4.0

1. Entries are added in the multimedia and system portions of the registry. When manually removing the software, use the Control Panel to "Remove" the driver (and delete these entries) *before* deleting individual files and registry entries.
2. In the main Windows NT ..\System32 directory, these files can be removed:
chewie.rbf
Hutt_merge.rbf
o540board.dll
o540vc.dll
o540_mix.dll
o540ausr.dll
o540_wav.dll
Oti.dll
otiyuv.dll
SimulKey2.dll
3. In the main Windows NT ..\System32\drivers directory, these files can be removed:
o540drv.sys
o540a.sys
4. The Osprey 540 install driver directory, its subdirectories, and its files can be removed. Typically, this directory is \Program Files\Osprey 540 on the default drive. The installation procedure puts the following files common to Windows NT in that directory:
CropApp.exe
CroppingManual.pdf
o540audstat.exe
Osprey-540 Special Offers.url
Osprey-540UsersGuide.pdf
osprey.ico
Readme.txt
SimulStream Special Offers.url
SimulStreaming_Users_Guide.pdf
VidCap.hlp
VidCap32.exe
xctlapp.exe
5. The installation program also creates a directory called NT within the Osprey 540 install directory which contains the following files:
files DelsL*.isu
VCLogo.bmp
VCST1.bmp
VCST2.bmp
the Help subdirectory and all its contents
6. In the registry the following branches are added and can be deleted without affecting the rest of the system. Use RegEdit to delete them.



In this branch of the registry, the "1" on wave, mixer, and msvideo may be a different numeral, or may not be present.

- ◆ HKEY_LOCAL_MACHINE\SOFTWARE\Microsoft\Windows NT\CurrentVersion\Drivers32 device entries:
 - "wave1"="o540_wav.dll"
 - "mixer1"="o540_mix.dll"
 - "msvideo1"="o540vc.dll - Osprey-540 Card 1"
 - ◆ HKEY_CURRENT_USER\Software\Osprey\Osprey540
 - ◆ HKEY_LOCAL_MACHINE\SOFTWARE\Microsoft\Windows NT\CurrentVersion\drivers.desc entries:
 - "o540vc.dll"="Osprey-540 Video Capture Driver"
 - "o540_wav.dll"="Osprey-540 Audio Wave Driver"
 - "o540_mix.dll"="Osprey-540 Audio Mixer Driver"
 - "o540board.dll"="Osprey-540 Audio Driver"
 - "o540ausr.dll"="Osprey-540 Audio Driver"
 - ◆ HKEY_LOCAL_MACHINE\SOFTWARE\Osprey\Osprey540
 - ◆ HKEY_LOCAL_MACHINE\SOFTWARE\ViewCast Corporation\Osprey Video Division\Osprey-540
 - ◆ HKEY_LOCAL_MACHINE\SOFTWARE\Microsoft\Windows\CurrentVersion\Uninstall\ {A056EAE0-AEFA-11D1-897C-00A02415A964}
 - ◆
 - ◆ HKEY_LOCAL_MACHINE\SYSTEM\CurrentControlSet\Services\o540drv
 - ◆ HKEY_LOCAL_MACHINE\SYSTEM\CurrentControlSet\Services\O540A
 - ◆ HKEY_USERS\.DEFAULT\Software\Osprey\Osprey540
 - ◆ HKEY_LOCAL_MACHINE\SOFTWARE\Microsoft\Windows NT\CurrentVersion\Drivers32 codec entries:
 - "vidc.I420 = otiyuv.dll"
 - "vidc.yuy2 = otiyuv.dll"
7. You can delete the Taskbar entry by selecting **Taskbar Properties -> Start Menu Programs -> Remove**.

Instructions for Windows 2000 and Windows XP

1. Entries are added in the multimedia and system portions of the registry. When manually removing the software, use the Control Panel to "Remove" the driver (and delete these entries) *before* deleting individual files and registry entries.
2. In the main Windows 2000 or Windows XP ..\System32 directory, these files can be removed:
 - Hutt_merge.rbf
 - chewie.rbf
 - o540vc.dll
 - o540_wav.dll
 - o540_mix.dll
 - o540ausr.dll
 - o540board.dll
 - otiyuv.dll
 - Ouno500.dll
 - OtiPnp.dll
 - SimulKey2.dll
3. In the main Windows 2000 or Windows XP ..\System32\drivers directory, these files can be removed:
 - o540drv.sys
 - o540a.sys
4. The Osprey-540 install driver directory, its subdirectories, and its files can be removed. Typically, this directory is \Program Files\Osprey 540 on the default drive. The installation procedure puts the following files common to Windows 2000 or Windows XP in that directory:
 - CropApp.exe
 - CroppingManual.pdf
 - osprey.ico
 - o540audstat.exe
 - Osprey-540 Special Offers.url
 - Osprey-540UsersGuide.pdf
 - Readme.txt
 - SimulStream Special Offers.url
 - SimulStreaming_Users_Guide.pdf
 - VidCap32.exe
 - VidCap.hlp
 - xctlapp.exe
5. The installation program also creates a directory called NT within the Osprey-540 install directory which contains the following files:
 - files DeIs*.isu
 - VCLogo.bmp
 - VCST1.bmp
 - VCST2.bmp
 - the Help subdirectory and all its contents

6. In the registry the following branches are added and can be deleted without affecting the rest of the system. Use RegEdit to delete them.



In this branch of the registry, the "1" on wave, mixer, and msvideo may be a different numeral, or may not be present.

- ◆ HKEY_LOCAL_MACHINE\SOFTWARE\Microsoft\Windows NT\CurrentVersion\Drivers32 device entries:
 "wave1"="o540_wav.dll"
 "mixer1"="o540_mix.dll"
 "msvideo1"="o540vc.dll - Osprey-540 Card 1"
 - ◆ HKEY_CURRENT_USER\Software\Osprey\Osprey540
 - ◆ HKEY_LOCAL_MACHINE\SOFTWARE\Microsoft\Windows NT\CurrentVersion\drivers.desc entries:
 "o540vc.dll"="Osprey-550 Video Capture Driver"
 "o540ausr.dll"="Osprey-540 Audio Driver"
 "o540_wav.dll"="Osprey-540 Audio Wave Driver"
 "o540_mix.dll"="Osprey-540 Audio Mixer Driver"
 "o540board.dll"="Osprey-540 Audio Board Driver"
 - ◆ HKEY_LOCAL_MACHINE\SOFTWARE\Osprey\Osprey540
 - ◆ HKEY_LOCAL_MACHINE\SOFTWARE\ViewCast Corporation\Osprey Video Division\Osprey-540
 - ◆ HKEY_LOCAL_MACHINE\SOFTWARE\Microsoft\Windows\CurrentVersion\Uninstall\ {A056EAE0-AEFA-11D1-897C-00A02415A964}
 - ◆
 - ◆ HKEY_LOCAL_MACHINE\SYSTEM\CurrentControlSet\Control\MediaResources\msvideo\!default entry: "Driver" = "o540vc.dll - Osprey-540 Card 1"
 - ◆
 - ◆ HKEY_LOCAL_MACHINE\SYSTEM\CurrentControlSet\Services\O540A
 - ◆ HKEY_LOCAL_MACHINE\SYSTEM\CurrentControlSet\Services\o540drv
 - ◆ HKEY_USERS\.DEFAULT\Software\Osprey\Osprey540
 - ◆ HKEY_LOCAL_MACHINE\SOFTWARE\Microsoft\Windows NT\CurrentVersion\Drivers32 codec entries:
 "vidc.I420 = otiyuv.dll"
 "vidc.yuy2 = otiyuv.dll"
7. You can delete the Taskbar entry by selecting **Taskbar Properties -> Start Menu Programs -> Remove**.

Appendix H - Adding/Moving Boards in Windows 2000 and Windows XP

Under **Windows 2000** or **Windows XP**, when the driver has been installed and another Osprey-540 board is put into a slot that has not previously contained a board, the following sequence of windows is initiated. This can happen because an Osprey-540 board has been moved to a different PCI slot or when a board is been added to the machine. It occurs because of the manner in which Windows 2000 and Windows XP enumerates devices.

Instructions for Windows 2000

Instructions for Windows XP

Instructions for Windows 2000

The New Hardware Wizard runs and displays two windows. A smaller window with the text "*Found New Hardware, Osprey-540 Video Capture Device, Installing ...*" (not shown here) may be obscured by the larger *Digital Signature Not Found* window.



1. Click **Yes**.

The Multimedia Video Controller installing window displays.



The text inside this window changes to "*Osprey-540 Audio Capture Device, Installing ...*" (not shown here). Then the following *Digital Signature Not Found* window displays on top of it.

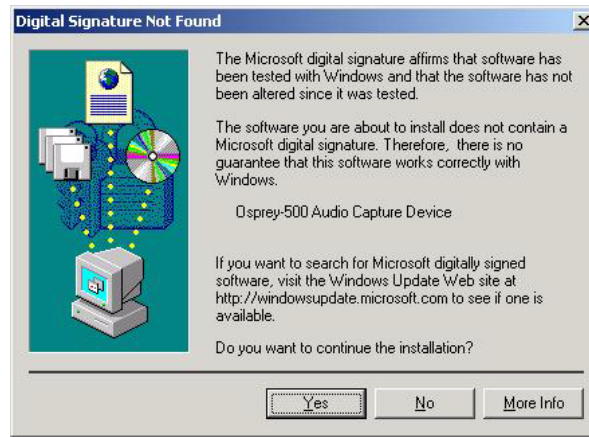

2. Click **Yes**.
3. When the *Completing the Found New Hardware* window displays, click **Finish**.
4. Two *Digital Signature Not Found* windows display for each Osprey-540 board that you have added or removed.
5. When the *Systems Settings Change* window displays indicating that you must restart your computer before the new settings take effect, click **Yes** to restart your computer.

Instructions for Windows XP

The New Hardware Wizard runs and displays two windows. A smaller window with the text "*Found New Hardware, Osprey-540 Video Capture Device, Installing ...*" (not shown here) may be obscured by the larger *Digital Signature Not Found* window.



1. Click **Install the software automatically**.
The Found New Hardware Wizard window displays.
2. Click **Next**.
The Found New Hardware Wizard window displays.

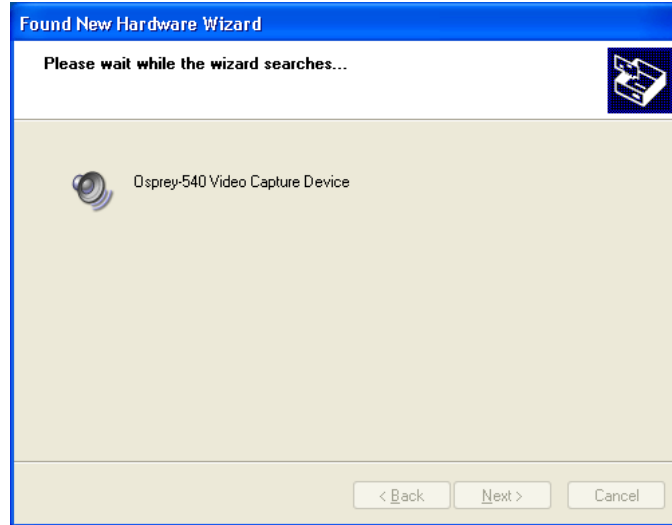

3. Click **Continue Anyway**.
The Found New Hardware Wizard window displays.

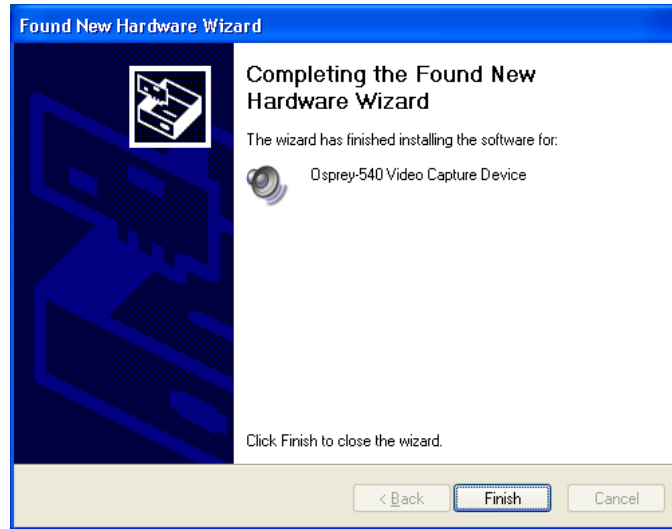

4. Click **Finish**.
The Found New Hardware Wizard window displays.



5. Click **Install the software automatically**.
The Found New Hardware Wizard window displays.
6. Click **Next**.
The Found New Hardware Wizard window displays.

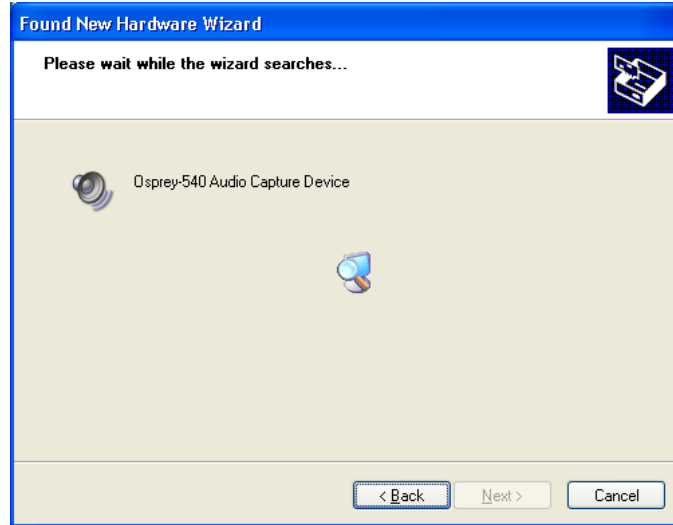

7. Click **Continue Anyway**.
The Found New Hardware Wizard window displays.

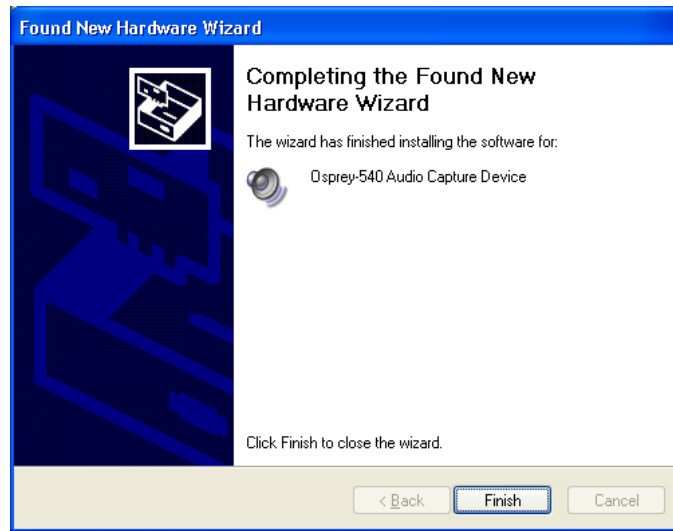

8. Click **Finish**.

Appendix I - Developer Support

The Osprey Technologies group has a software developers' kit (SDK) to assist development of specialized Video for Windows applications. The Osprey Video for Windows NT/2000/XP SDK provides capabilities that the Video for Windows API does not provide. It uses a proprietary interface that bypasses Video for Windows and connects your application directly to the Osprey video capture driver.

The developers' kit at present has the following modules:

- ◆ Methods by which a single application can access multiple boards - see also Appendix F.
- ◆ Interactive control of video source, brightness, contrast, hue, and saturation from inside an application
- ◆ A Closed Captioning API, by which the application can control Closed Captioning and capture Closed Caption text for specialized processing and display.
- ◆ An API for Controlling on-video logos - see Chapter 6, [The Logo Page](#).
- ◆ An API for capture of raw Vertical Blanking Interval (VBI) data.
- ◆ Direct access to the Bt878 registers.
- ◆ Please inquire at <mailto:info@ospreyvideo.com> for further information.

